

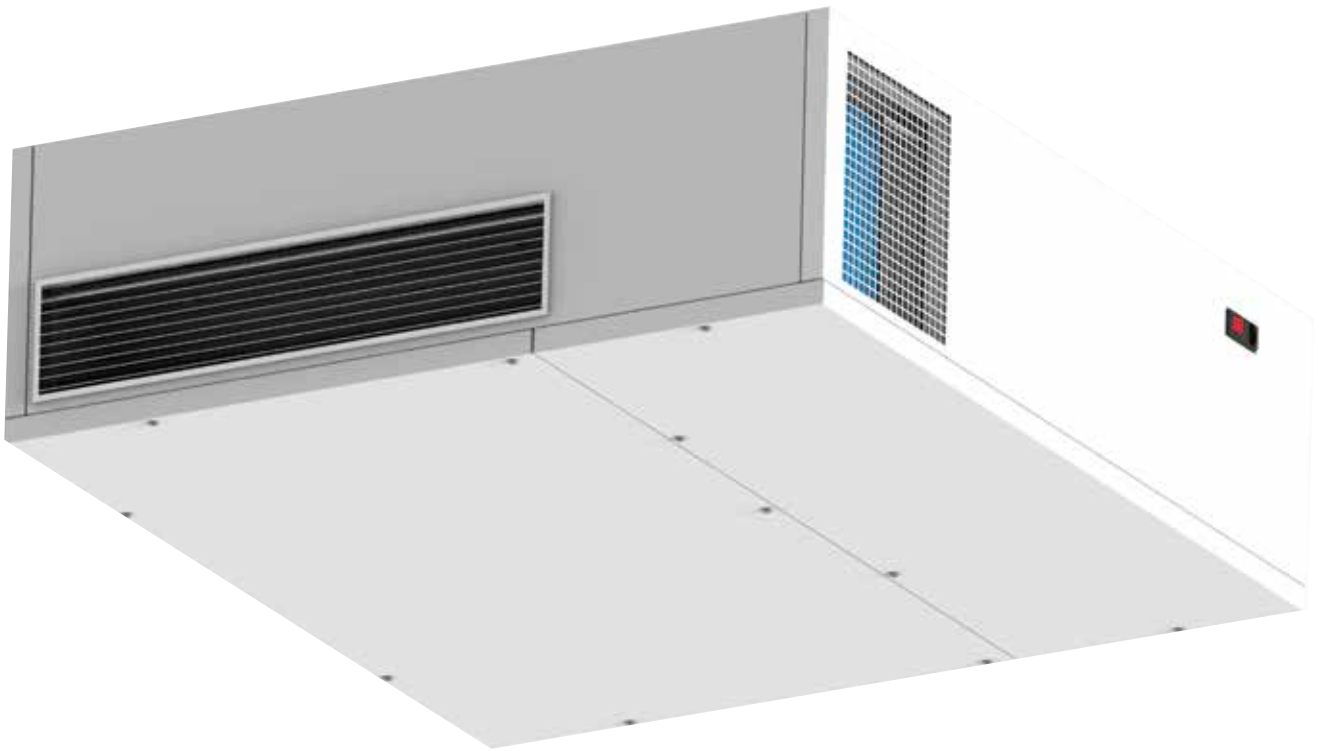

indoor air quality and energy saving

TECHNICAL DATA



UHS 400-800

Horizontal unit for school



VENTILATION UNIT WITH HEAT RECOVERY FOR COMMERCIAL AND INDUSTRIAL BUILDINGS



UHS

Non-residential dual flow ventilation unit with high efficiency heat recovery.

PERFORMANCE

Equipped with an aluminum counterflow heat exchanger (Eurovent certified) and EC electronic fans. The standard automatic total bypass makes it possible to take advantage of favorable conditions outside the building for free cooling (or free heating) in automatic mode. Noise for both sizes, 35 dBA

STRUCTURE

UHS is made with self-supporting zinc magnesium panels insulated with rock wool. The panels, internal components and exterior of the unit are made of aluminum. Filters (ePM1 70% (F7) for fresh air flow and (ePM1 70% (F7) for extract air flow. UHS is designed to be installed inside buildings. It can be equipped with air post treatment systems (inside the unit) such as: electric pre/post heater.

CONTROLS

UHS is supplied complete with electrical panel and control system; the version equipped with EVO-PH control and the version equipped with EVOD-PH-IP control are available, designed for complete integration into home automation systems (Modbus protocol with Ethernet connection or, on request, with the addition of the RS485 connection). The new version of our control systems allows the passage from one control system to another with extreme ease and speed, even after installation with only the replacement of the remote panel.

The EVO-PH control has a color backlit touch screen interface which allows an intuitive view of the operating status of the machine; it allows precise adjustment of the fan speed and has a weekly time schedule for automatic management of the fans. EVO-PH can be controlled by an external switch to activate the booster function; it can automatically adjust the air flow if connected to an air quality probe; it can manage any air post-treatment accessories, it automatically manages the bypass and prevents frosting of the heat exchanger by managing the speed of the fans or, if installed, an electric preheating resistance (optional accessory inside the machine); signals to the user the need to replace the filters (the clogging status of the filters is monitored by a pair of standard differential pressure switches) or the onset of an anomaly, indicating its origin.

The EVOD-PH-IP controller has the same features as the EVO-PH version with the addition of the Modbus communication protocol which allows full control of the machine by the home automation system supervision software. The implemented webserver allows you to interact with the machine even with an internet browser of a device connected (even remotely) to the home automation network in which the machine itself is inserted.

ACCESSORIES

UHS can be equipped with other accessories such as:

- . R.H., CO₂ or CO₂/VOC probe
- . condensate pump (allows water, contained inside the drainage tank, to go up and come out from the drain placed on the upper panel)

For a more complete view of the characteristics of the control systems, please refer to the respective manuals.

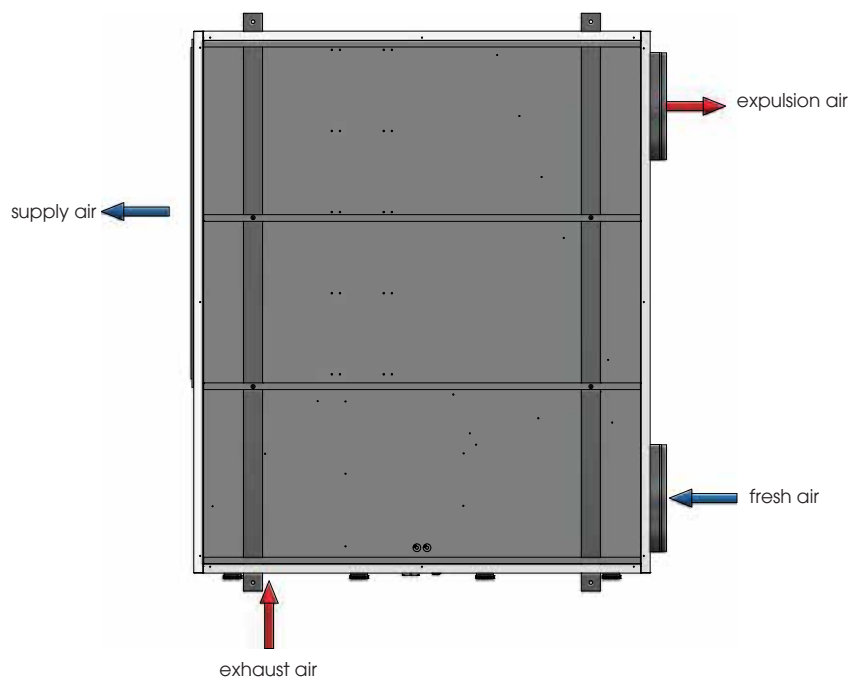



AERULIC PERFORMANCE (UNI EN 13141-7)

The unit must be ducted: its use is authorized only within the curve shown.

The declared performances are with CLEAN filters, and guaranteed EXCLUSIVELY with the original UTEK low pressure drop filters.

UHS 400

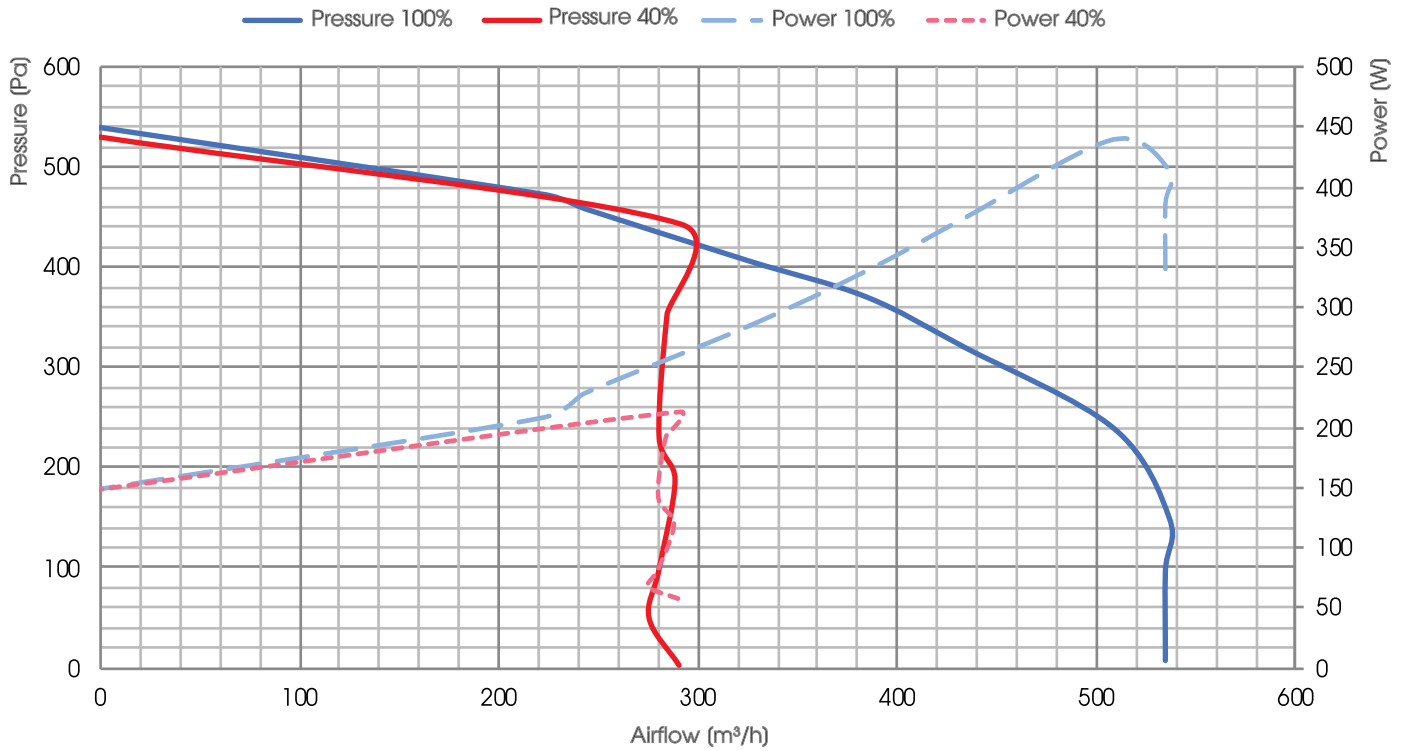

UHS 800

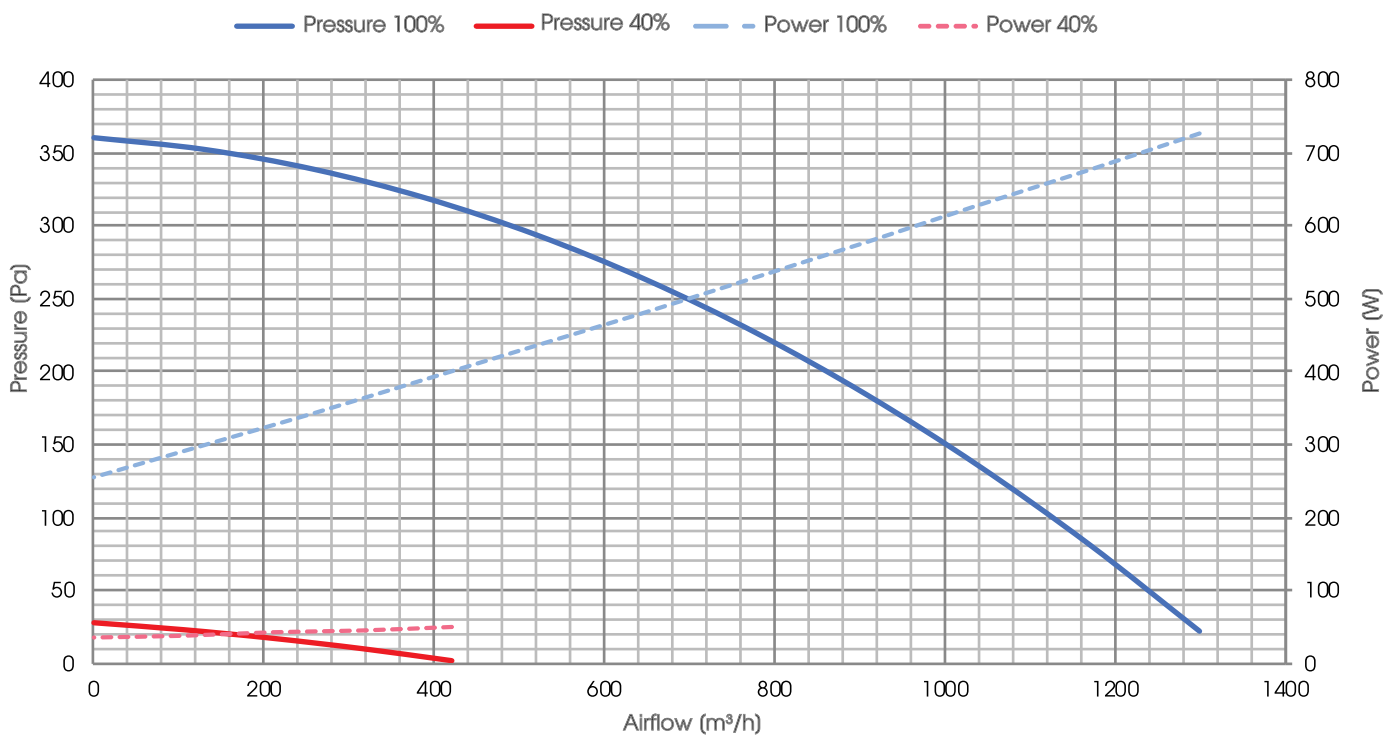



SENSITIVE HEAT RECOVERY EFFICIENCY

Values referred to the following conditions (UNI EN 13141-7): Tbs external air 5°C; U.R. external 72%; ambient Tbs 25°C; U.R. environment 28%

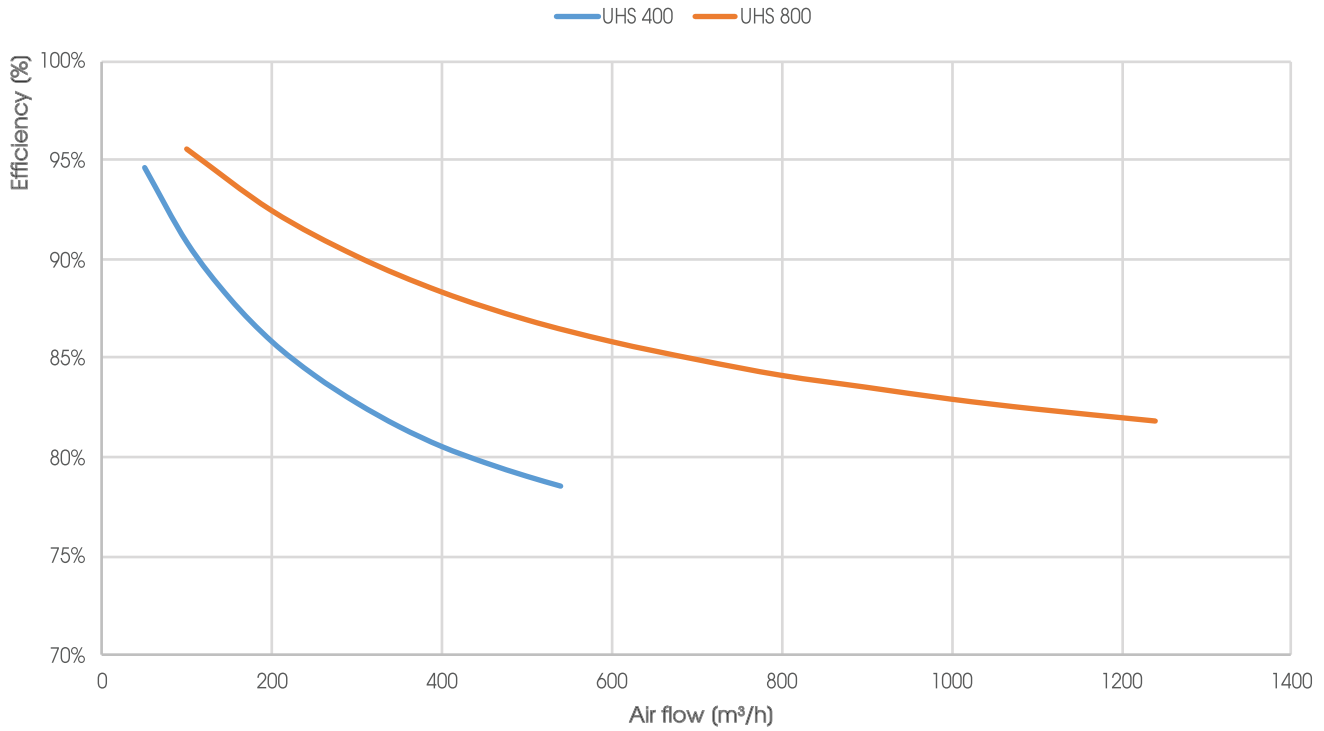

TEST LEAKAGE UNI EN 13141-7

LEAKAGE	TEST CONDITIONS	UHS 400 CLASS	UHS 800 CLASS
OUTDOOR	Positive pressure 400 Pa	A3	A3
OUTDOOR	Negative pressure 400 Pa	A3	A3
INDOOR	Pressure difference 250 Pa	A3	A3

NOISE LEVEL

UHS 400 - Sound power level L_w									
Sound Power (dB)								L _{WA}	Pressure 3m Q=4
Speed	125 Hz	250 Hz	500 Hz	1kHz	2kHz	4kHz	8kHz	dB(A)	dB(A)
100%	60,0	62,0	53,0	51,0	44,0	41,0	34,0	57,1	42,6
40%	47,2	46,6	37,7	38,1	27,3	23,0	17,7	42,6	28,1

UHS 800 - Sound power level L_w									
Sound Power (dB)								L _{WA}	Pressure 3m Q=4
Speed	125 Hz	250 Hz	500 Hz	1kHz	2kHz	4kHz	8kHz	dB(A)	dB(A)
100%	64,0	61,0	51,0	52,0	46,0	50,0	37,0	58,0	43,5
40%	33,5	31,9	28,8	26,1	18,1	20,5	14,2	31,1	16,6

ELECTRICAL DATA

Unit	FAN					UHS	
	Model	Nominal power	Supply	Nominal current	Insulation class	Supply	Current max.(A)
UHS 400	EC d160	110 W	230 V, 50/60 Hz 1F	0,85	IP 44, CLASS B	230 V, 50 Hz 1F	3,4
UHS 800	EC d200	380 W	230 V, 50/60 Hz 1F	1,70	IP 44, CLASS B	230 V, 50 Hz 1F	4,4



Dimensions (mm) e Weight (kg)

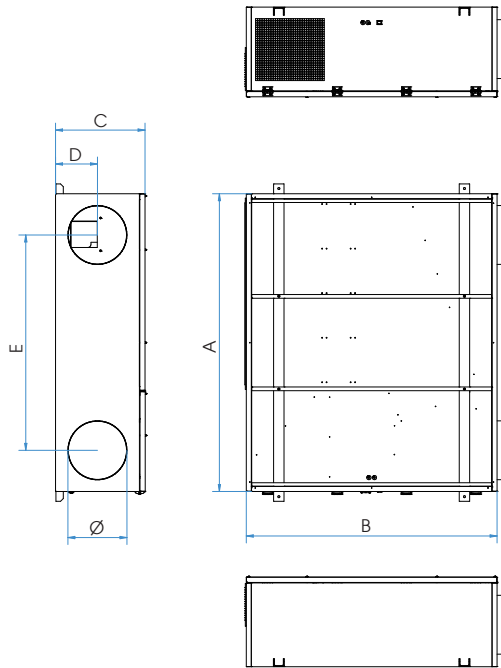

	UHS 400	UHS 800
A (mm)	1105	1605
B (mm)	1130	1350
C (mm)	360	480
D (mm)	182	225
E (mm)	710	1160
Ø (mm)	250	315
Weight (mm)	130	185

ECODESIGN

MOD.	$\eta_{t,nvr}$ (%)	q_{nom} (m ³ /s)	$\Delta p_{s,ext}$ (Pa)	P (kW)	SFP _{int} (W/(m ³ /s))	SFP _{int_lim 2016} (W/(m ³ /s))	SFP _{int_lim 2018} (W/(m ³ /s))	FRONT SPEED (m/s)	$\Delta p_{s,int}$ (Pa)	η_{Fan} (%)	* LEAKAGE internal (%)	* LEAKAGE external (%)
UHS 400	78,7%	0,15	200	0,43	1227	1530	1250	2,10	348	28,5	10,0	9,6
UHS 800	83,7%	0,24	200	0,56	1052	1666	1386	0,75	369	36,9	11,6	13,5

* Percentage of nominal flow rate

CLA & UTEK reserves the right to make the changes necessary to improve the products at any time, without prior notice.

Dear Customer

Thank you for your attention to the UTEK product, designed and manufactured to guarantee the User real values: Quality, Safety and Savings on consumption.



Made in Italy

**AZIENDA CON SISTEMA
DI GESTIONE QUALITÀ
CERTIFICATO DA DNV GL
ISO 9001**

**AZIENDA CON
SISTEMA DI GESTIONE
AMBIENTALE CERTIFICATO
DA DNV
ISO 14001**



the Dealer

UHS_2023_0_EN



VENTILATION UNIT WITH HEAT RECOVERY FOR COMMERCIAL AND INDUSTRIAL BUILDINGS