

# HBF F400/ HBFX

Axial fan F400

Ventilador helicoidal F400

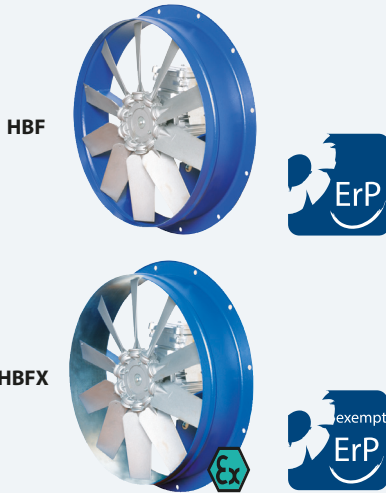

### MANUFACTURING FEATURES

- Axial fan with circular reinforced frame.
- Modular motor-impeller assembly.
- Impeller in aluminum injection with reinforced body. Protected against corrosion by powder coating of polyester resin.
- HBFX with protection ring made of aluminium.
- Standard asynchronous squirrel cage motor with IP-55 protection and Class H insulation certified 400°C/2h. Standard voltages 230/400V 50Hz in three phase motors up to 3kW and 400/690V 50Hz for higher powers. IE3 efficiency motor from 0,75kW up to 45kW in single speed.

### APPLICATIONS

- Designed for wall or duct installation, they are suitable for:
- Smoke emergency exhaust with motor inside the hazardous area.
  - Maximum working temperature: 60°C.

### UNDER REQUEST

- B Form impeller (air flow from impeller to motor). 5% additional cost.
- 100% reversible impeller. 5% additional cost.

### CARACTERÍSTICAS CONSTRUCTIVAS

- Ventilador helicoidal de marco redondo reforzado.
- Montaje modular del conjunto motor hélice.
- Hélice en inyección de aluminio con nervio intermedio. Protegidos contra la corrosión mediante recubrimiento en polvo de resina de poliéster.
- Anillo de protección en aluminio para HBFX.
- Motor asíncrono normalizado de jaula de ardilla con protección IP-55 y aislamiento clase H homologado para 400°C/2h. Voltajes estándar 230/400V 50Hz para motores trifásicos hasta 3kW y 400/690V 50Hz para potencias superiores. Motor de eficiencia IE3 desde 0,75kW hasta 45kW de una velocidad.

### APLICACIONES

- Diseñados para montaje en pared o en conducto, son indicados para:
- Extracción de humo en caso de incendio estando el motor dentro de la zona de riesgo.
  - Temperatura máxima de trabajo en continuo: 60°C.

### BAJO DEMANDA

- Hélice impelente (sentido de aire hélice-motor). Incremento 5% sobre PVP.
- Hélice reversible 100%. Incremento 5% sobre PVP.



## ACCESSORIES / accesorios

<p><b>INT</b> Interruptor de corte Safety switch</p>	<p><b>PC2</b> Rejilla de sobrepresión antirretorno Overpressure damper for facade</p>	<p><b>INT 400</b> Interruptor selector de velocidad Speed selector switch</p>	<p><b>SFC</b> Variador de velocidad frecuencial Frequency speed controller</p>
<p><b>RPO</b> Rejilla protección impulsión Outlet protection guard</p>	<p><b>RP1</b> Rejilla protección aspiración Inlet protection guard</p>	<p><b>AC</b> Brida conexión Connection flange</p>	<p><b>BA-400</b> Brida antivibratoria 400°C/2h Flexible flange 400°C/2H</p>
<p><b>MC HB</b> Marco soporte cuadrado para HB Square mounting frame for HB</p>	<p><b>JE 45</b> Junta elástica Flexible joint</p>	<p><b>BAD</b> Brida de acoplamiento circular-circular Circular-Circular coupling flange</p>	<p><b>INT ATEX</b> Interruptor para funcionar en entornos ATEX. Switch for ATEX environments.</p>

## THREE PHASE RANGE / serie trifásica

### 4 POLE / 4 polos

Model	Angle	Min. Rat. power kW	Max. Rat. power kW	Air flow m <sup>3</sup> /h	Sound dB (A) **	Weight Kg *	Connection diagram
HBF 45 T4 (A5:6) F400	20° - 42,5°	0,75	0,75	-	51	15,40	1
HBF 50 T4 (A5:6) F400	25° - 45°	0,75	0,75	-	55	19,70	1
HBF 56 T4 (A5:6) F400	20° - 45°	0,75	1,5	14.630	70	22,50	1
HBF 63 T4 (A5:6) F400	20° - 45°	0,75	3	20.340	74	26,50	1
HBF 71 T4 (A5:6) F400	20° - 45°	0,75	3	27.510	79	30,60	1
HBF 80 T4 (A5:6) F400	20° - 45°	2,2	4	34.460	76	36,30	1
HBF 90 T4 (A3:4) F400	20° - 42°	3	15	48.110	73	58	1
HBF 90 T4 (A3:8) F400	20° - 42°	3	15	54.810	78	63,10	1
HBF 100 T4 (A3:4) F400	20° - 42°	5,5	22	67.210	72	70,30	1
HBF 100 T4 (A3:8) F400	20° - 42°	5,5	22	77.810	81	75,90	1
HBF 112 T4 (A3:4) F400	20° - 42°	7,5	37	92.110	76	79	1
HBF 112 T4 (A3:8) F400	20° - 42°	7,5	37	104.010	83	85,10	1
HBF 125 T4 (A3:4) F400	20° - 42°	11	45	124.010	83	88,70	1
HBF 125 T4 (A3:8) F400	20° - 42°	11	45	141.010	89	95,30	1

**6 POLE / 6 polos**

Model	Angle	Min. Rat. power kW	Max. Rat. power kW	Air flow m <sup>3</sup> /h	Sound dB (A) **	Weight Kg *	Connection diagram
HBF 45 T6 (A5:6) F400	25° - 45°	0,55	0,75	-	42	15,40	1
HBF 50 T6 (A5:6) F400	25° - 45°	0,55	0,75	-	46	19,70	1
HBF 56 T6 (A5:6) F400	20° - 45°	0,55	0,75	9.760	67	22,50	1
HBF 63 T6 (A5:6) F400	20° - 45°	0,55	0,75	13.560	71	26,50	1
HBF 71 T6 (A5:6) F400	20° - 45°	0,55	1,1	18.340	76	30,60	1
HBF 80 T6 (A5:6) F400	20° - 45°	0,75	2,2	25.190	72	36,30	1
HBF 90 T6 (A3:4) F400	20° - 42°	1,5	5,5	31.210	63	58	1
HBF 90 T6 (A3:8) F400	20° - 42°	1,5	5,5	35.510	68	63,10	1
HBF 100 T6 (A3:4) F400	20° - 42°	1,5	7,5	43.610	63	70,30	1
HBF 100 T6 (A3:8) F400	20° - 42°	1,5	7,5	50.410	71	75,90	1
HBF 112 T6 (A3:4) F400	20° - 42°	2,2	11	59.710	66	79	1
HBF 112 T6 (A3:8) F400	20° - 42°	2,2	11	67.610	73	85,10	1
HBF 125 T6 (A3:4) F400	20° - 42°	3	18,5	80.610	73	88,70	1
HBF 125 T6 (A3:8) F400	20° - 42°	3	18,5	91.410	80	95,30	1

**THREE PHASE RANGE 2 SPEEDS / serie trifásica 2 velocidades**
**4/8 POLE / 4/8 polos**

Model	Angle	Min. Rat. power kW	Max. Rat. power kW	Air flow m <sup>3</sup> /h	Sound dB (A) **	Weight Kg *	Connection diagram
HBF 45 T4/T8 (A5:6) F400	20° - 45°	0,6	1,6	7.300	51	15,4	1
HBF 50 T4/T8 (A5:6) F400	20° - 45°	0,6	1,6	9.500	55	19,7	1
HBF 56 T4/T8 (A5:6) F400	20° - 45°	0,6	2,8	14.630	70	22,5	2
HBF 63 T4/T8 (A5:6) F400	20° - 45°	0,6	2,8	20.340	74	26,5	2
HBF 71 T4/T8 (A5:6) F400	20° - 45°	0,6	4	27.510	79	30,6	2
HBF 80 T4/T8 (A5:6) F400	20° - 45°	1,2	7,5	34.460	76	36,3	2
HBF 90 T4/T8 (A3:4) F400	20° - 42°	2,2	17	48.110	73	58	2
HBF 90 T4/T8 (A3:8) F400	20° - 42°	2,2	17	54.810	78	63,1	2
HBF 100 T4/T8 (A3:4) F400	20° - 42°	4	20	67.210	72	70,3	2
HBF 100 T4/T8 (A3:8) F400	20° - 42°	4	20	77.810	81	75,9	2
HBF 112 T4/T8 (A3:4) F400	20° - 42°	5,5	37	92.110	76	79	2
HBF 112 T4/T8 (A3:8) F400	20° - 42°	5,5	37	104.010	83	85,1	2
HBF 125 T4/T8 (A3:4) F400	20° - 42°	7,5	44	124.010	83	88,7	2
HBF 125 T4/T8 (A3:8) F400	20° - 42°	7,5	44	141.010	89	95,3	2

\*\* Total sound pressure level at the point of maximum flow measured in dB(A) in the suction measured in free field at a distance of 6m from the source.

\*\* Nivel de presión sonora total en el punto de caudal máximo medido en dB(A) en la aspiración, medido en campo libre a una distancia de 6m de la fuente.

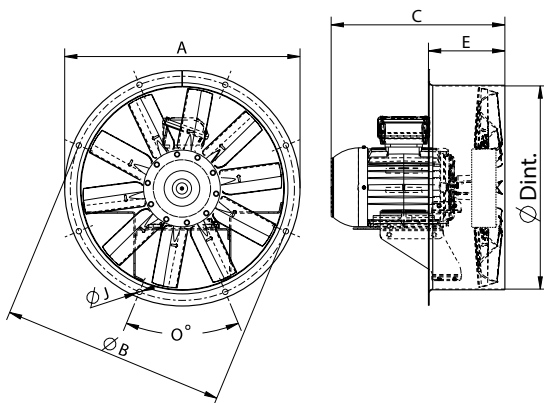
**DIMENSIONS / dimensiones**

MODEL	ØA	ØB	ØD	E	ØI	O
HBF 45	525	500	452	170	12	8x45°
HBF 50	600	560	504	170	12	12x30°
HBF 56	646	620	559	175	12	12x30°
HBF 63	725	690	633	185	12	12x30°
HBF 71	802	770	715	190	12	16x22,5°
HBF 80	892	860	801	220	12	16x22,5°
HBF 90	1000	970	903,5	340	12	16x22,5°
HBF 100	1115	1070	1013	340	12	16x22,5°
HBF 112	1234	1190	1132	340	12	16x22,5°
HBF 125	1365	1320	1263	340	15	20x18°

C' max. Aprox. (Consult motor size table / Consultar tabla tamaño constructivo motor)

model	63	71	80	90S	90L	100L	112M	132S	132M	160M	160L	180M	180L	200	225
HBF 45	328	328	347	362	387	418	-	-	-	-	-	-	-	-	-
HBF 50	-	338	350	362	387	421	-	-	-	-	-	-	-	-	-
HBF 56	-	338	352	362	387	423	-	-	-	-	-	-	-	-	-
HBF 63	-	-	352	386	411	442	463	-	-	-	-	-	-	-	-
HBF 71	-	-	357	391	416	447	468	-	-	-	-	-	-	-	-
HBF 80	-	-	-	427	427	463	469	525	563	-	-	-	-	-	-
HBF 90	-	-	-	-	-	658	658	658	658	721	742	778	787	-	-
HBF 100	-	-	-	-	-	-	-	653	653	716	738	776	792	-	-
HBF 112	-	-	-	-	-	-	-	760	760	760	760	761	780	864	949
HBF 125	-	-	-	-	-	-	-	759	759	759	759	760	779	863	948

MOTOR SIZE DEPENDING ON POWER (1 SPEED) / TAMAÑOS CONSTRUCTIVOS DE MOTORES SEGÚN POTENCIA (1 VELOCIDAD)

	Kw																		
	0,075	0,09	0,12	0,18	0,25	0,37	0,55	0,75	1,1	1,5	2,2	3	4	5,5	7,5	11	15	18,5	22
M2-T2 (3000rpm)	-	56	56	63	63	71	71	80	80	90S	90L	100L	112M	132S	132S	160M	160M	160L	180M
M4-T4 (1500rpm)	56	56	63	63	71	71	80	80	90S	90L	100L	100L	112M	132S	132M	160M	160L	180M	180L
M6-T6 (1000rpm)	-	63	-	71	71	80	80	90S	90L	100L	112M	132S	132M	132M	160M	160L	180L	200L	200L
M8-T8 (750rpm)	-	71	71	80	80	90S	90L	100L	100L	112M	132S	132M	160M	160M	160L	180L	200L	225S	225M

CONNECTION DIAGRAMS / esquema de conexiones

1 THREE PHASE MOTORS 1 SPEED / motores trifásicos 1 velocidad

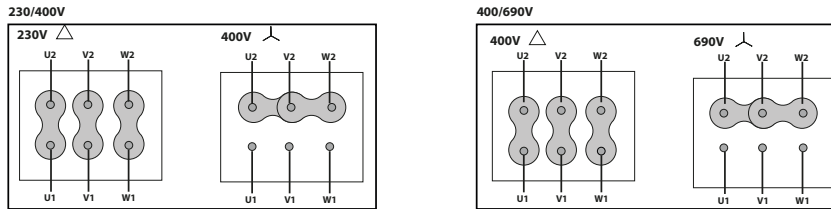

2 2 SPEEDS / 2 velocidades 400V DAHLANDER (Y,YY)

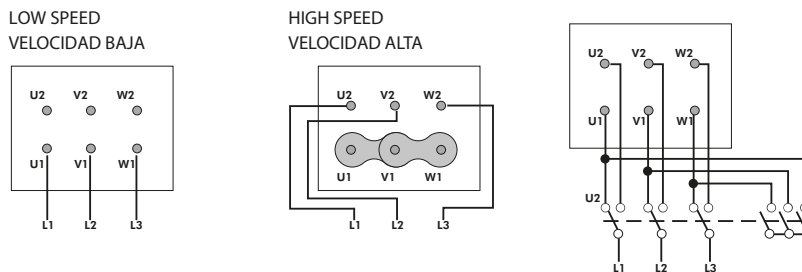



**CHARACTERISTIC CURVES / curvas características**

**HBF 45 T4 (A5:6) F400**

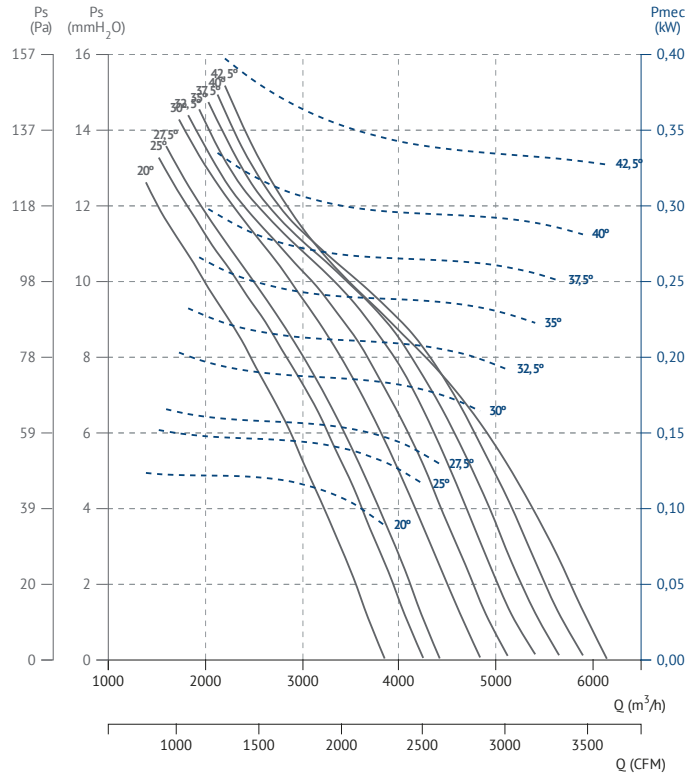

**HBF 45 T6 (A5:6) F400**

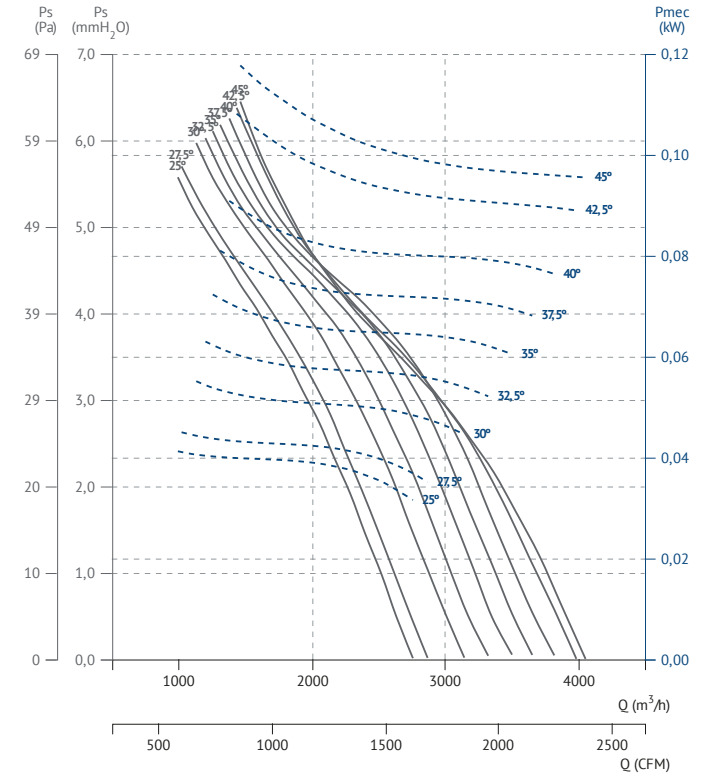

**HBF 50 T4 (A5:6) F400**

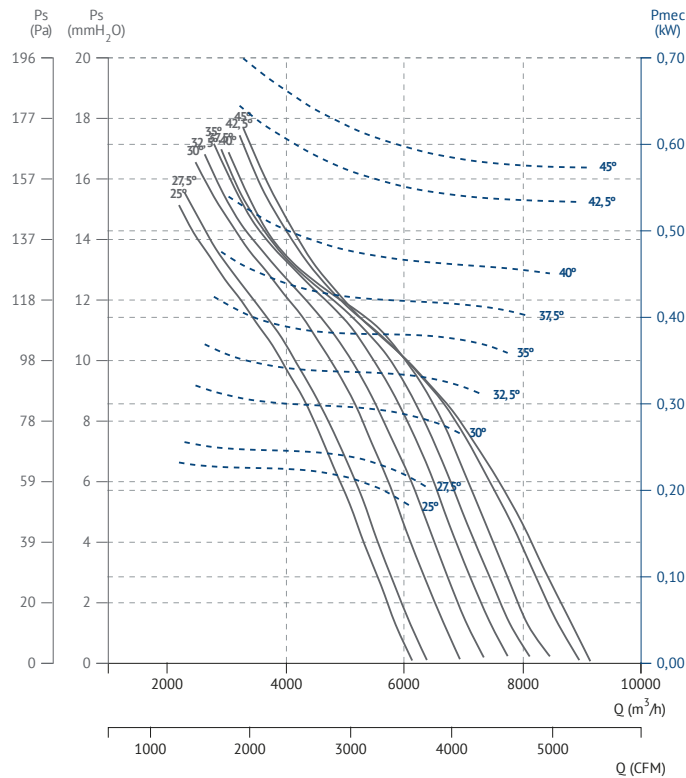

**HBF 50 T6 (A5:6) F400**

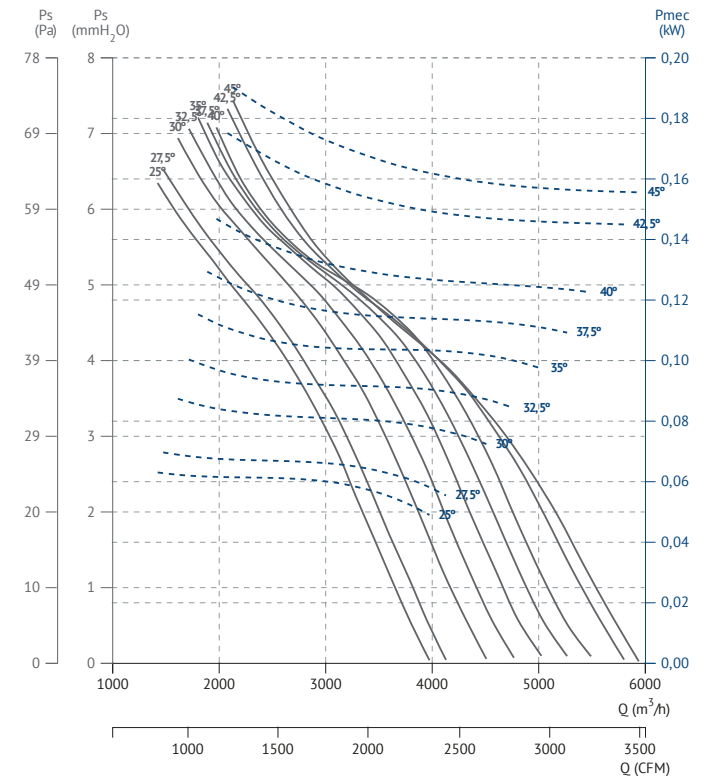



**HBF 56 T4 (A5:6) F400**

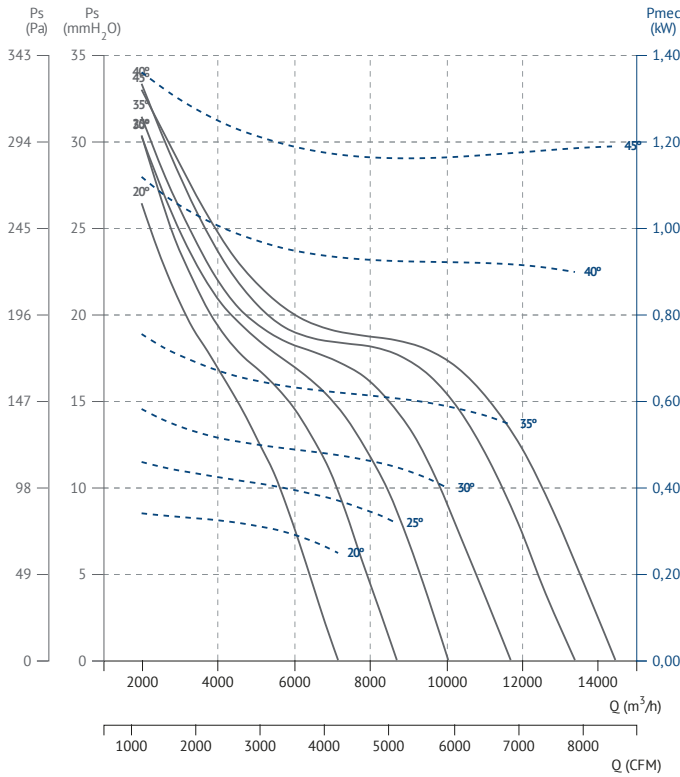

**HBF 56 T6 (A5:6) F400**

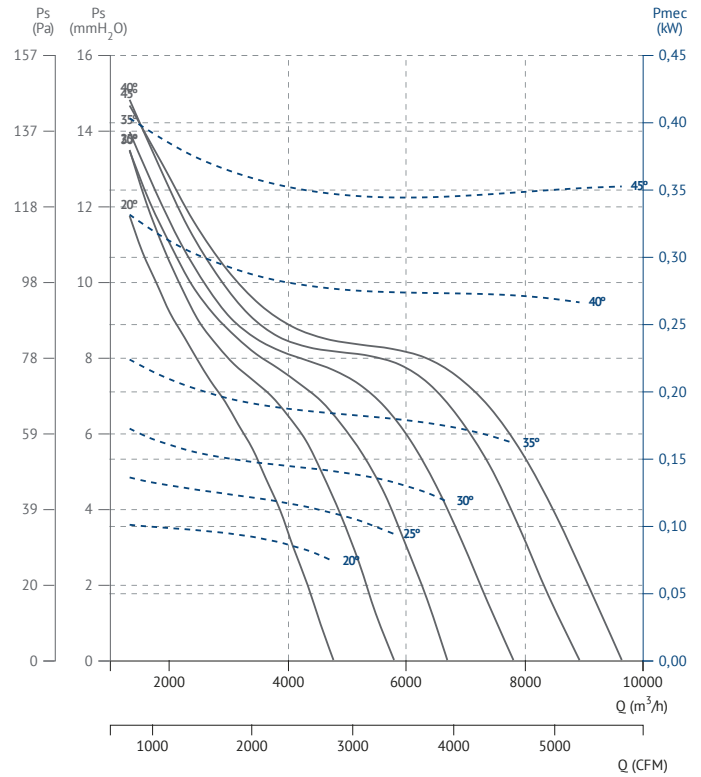

**HBF 63 T4 (A5:6) F400**

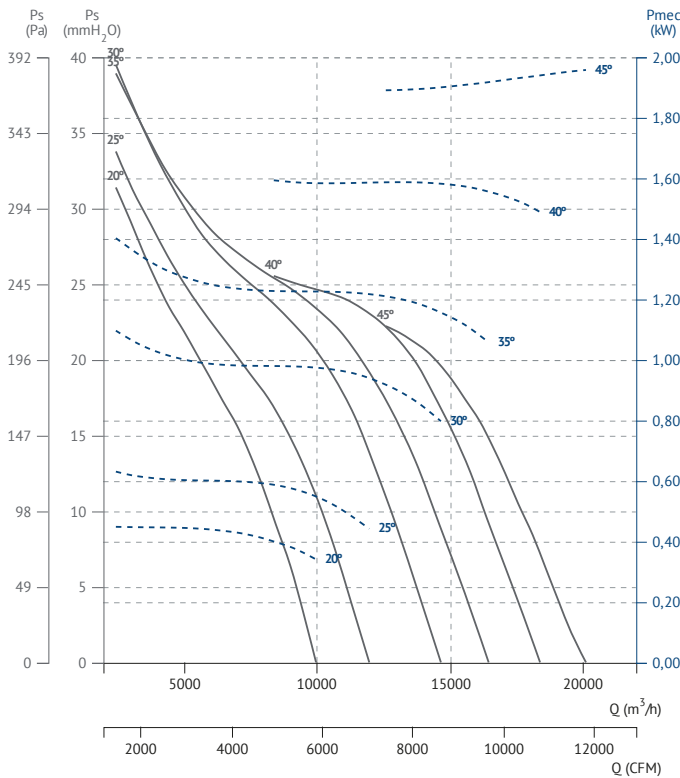

**HBF 63 T6 (A5:6) F400**

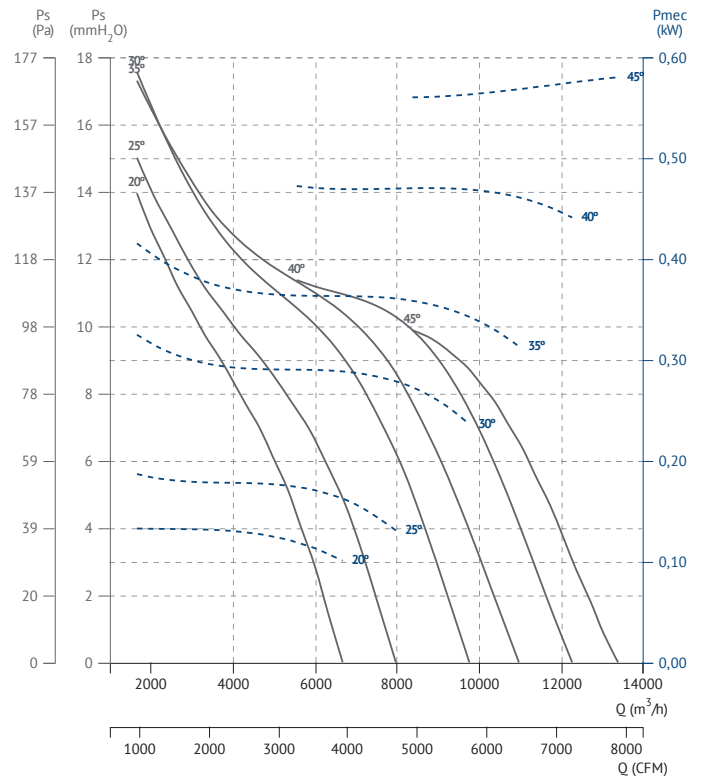



**HBF 71 T4 (A5:6) F400**

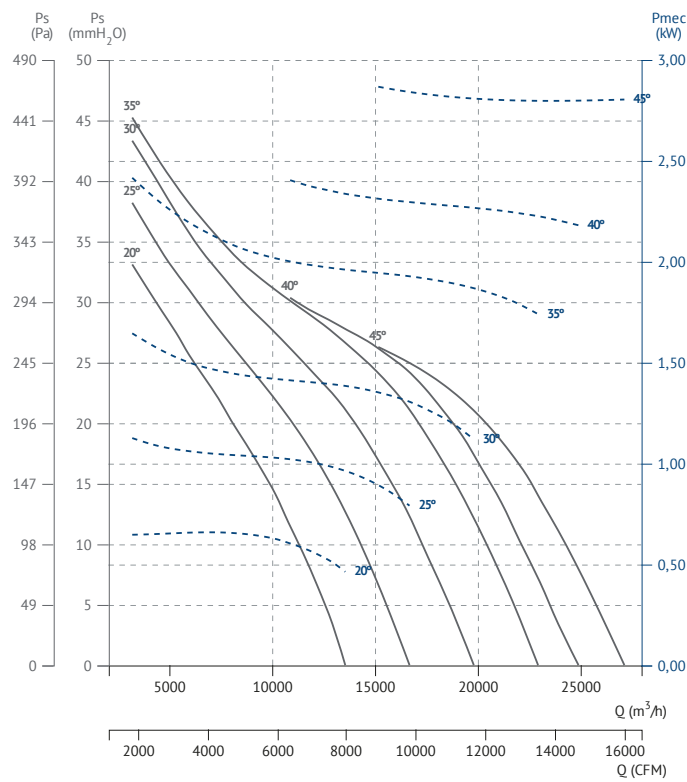

**HBF 71 T6 (A5:6) F400**

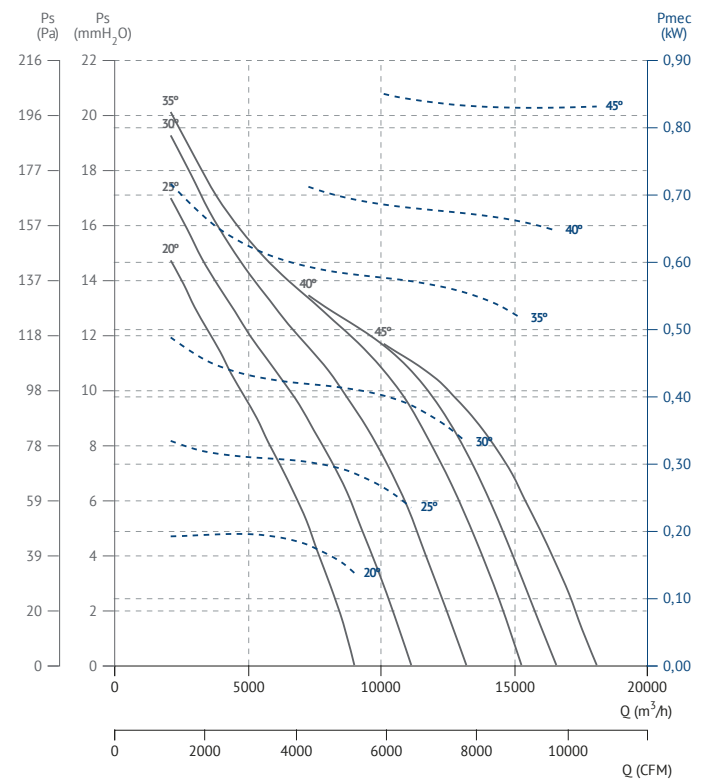

**HBF 80 T4 (A5:6) F400**

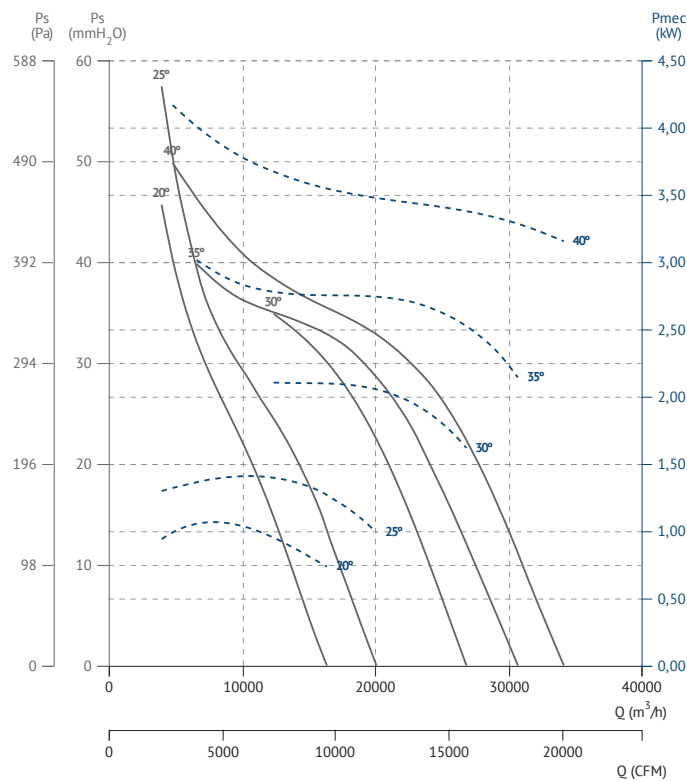

**HBF 80 T6 (A5:6) F400**

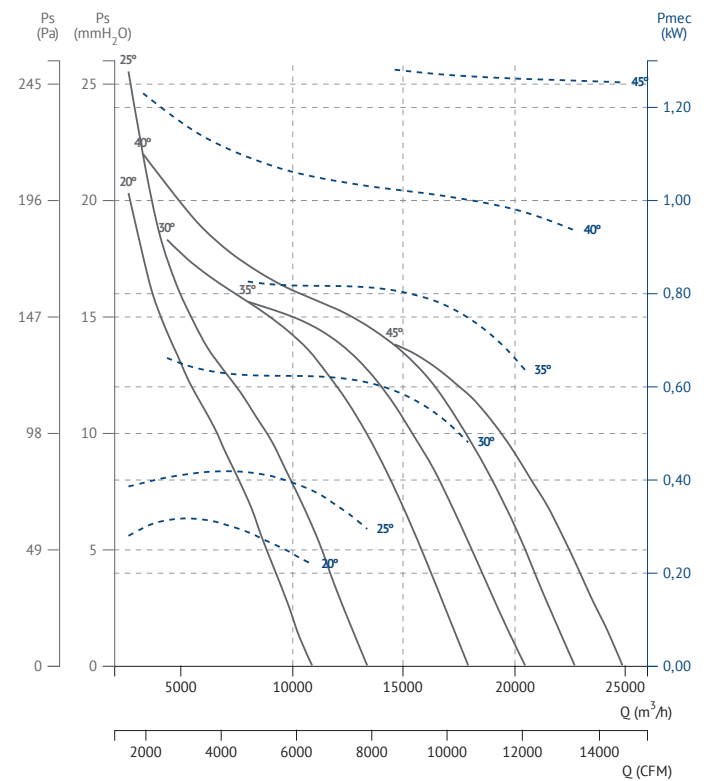



SMOKE EXHAUST/ INSIDE 400°C/2h, 300°C/2h, 200°C/2h

Desenfumaje/ inmersos 400°C/2h, 300°C/2h, 200°C/2h

Homologación oficial APPLUS según norma EN 12101-3:2015

**HBF 90 T4 (A3:4) F400**

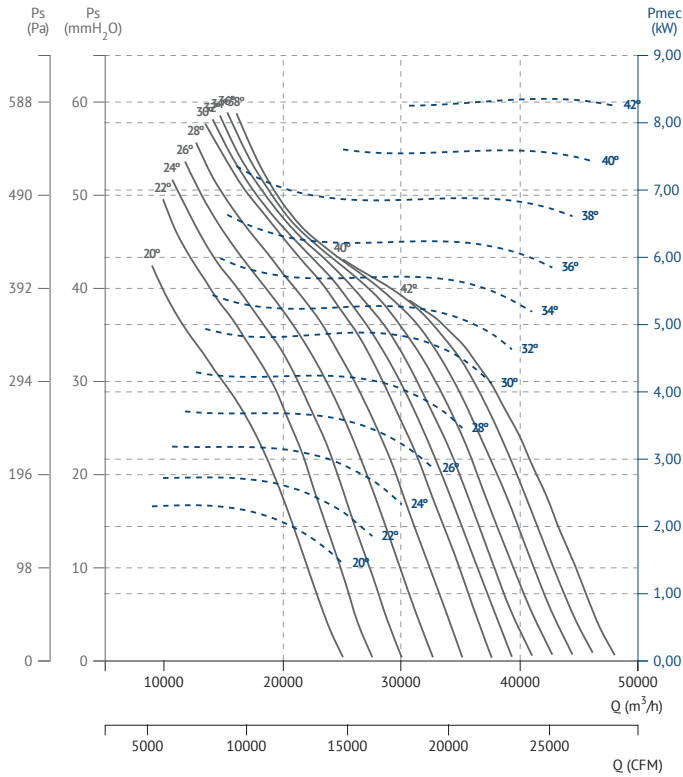

**HBF 90 T4 (A3:8) F400**

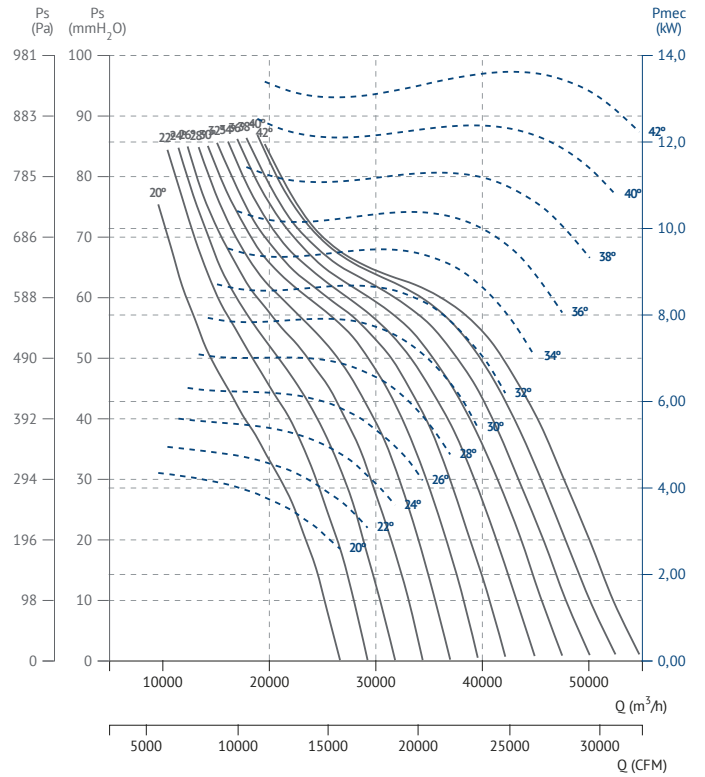

**HBF 90 T6 (A3:8) F400**

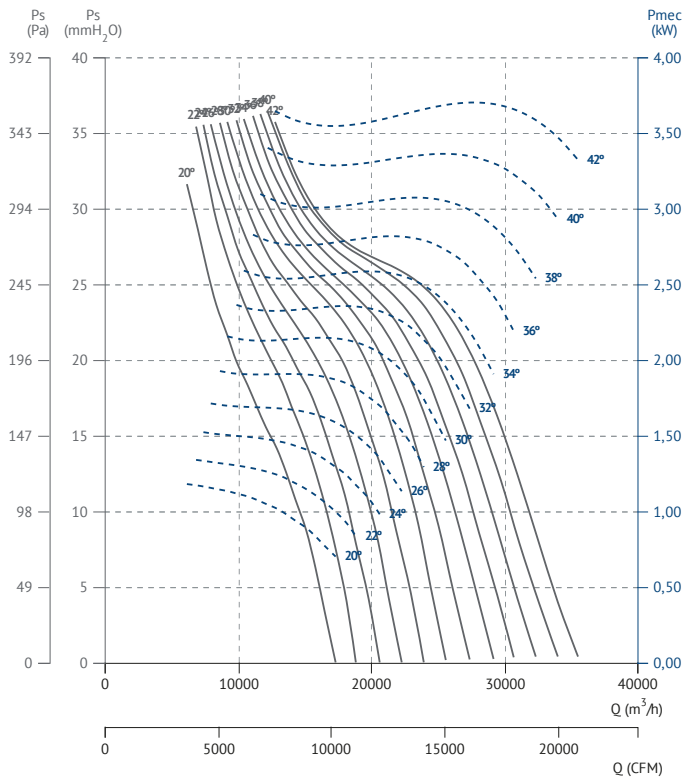

**HBF 90 T6 (A3:4) F400**

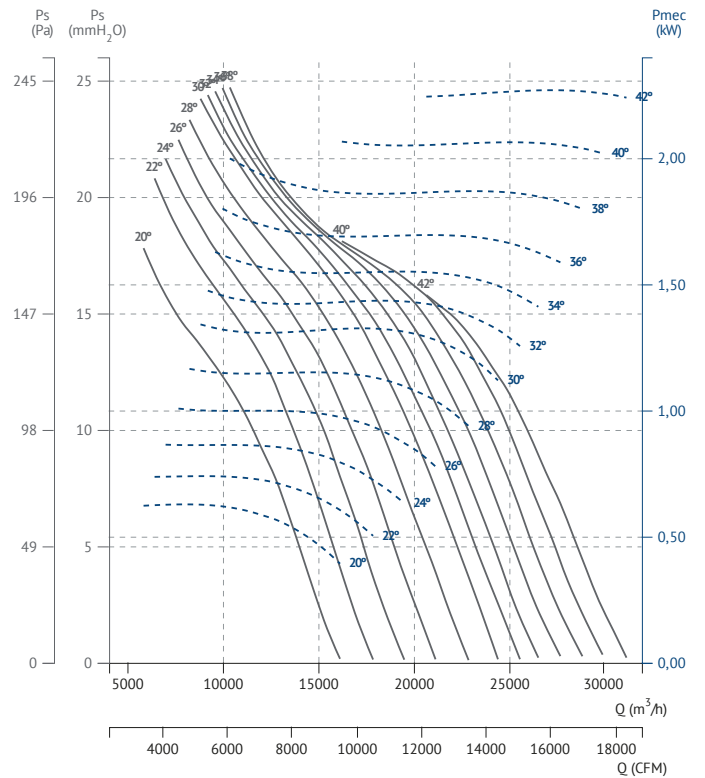



**HBF 100 T4 (A3:4) F400**

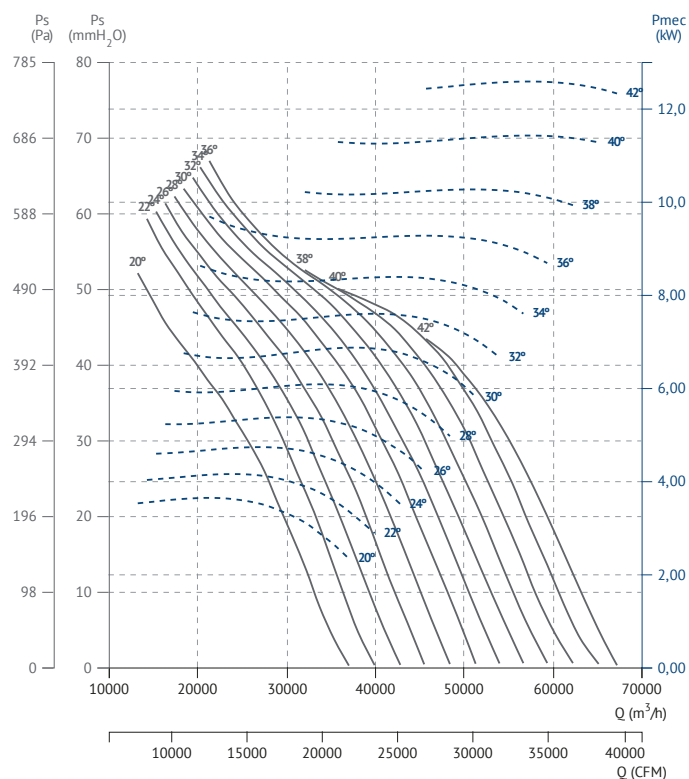

**HBF 100 T4 (A3:8) F400**

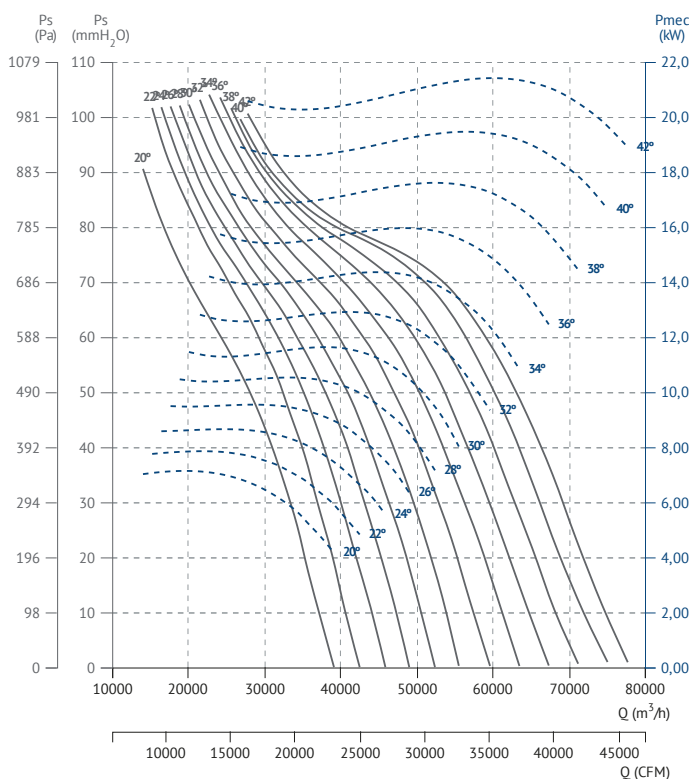

**HBF 100 T6 (A3:4) F400**

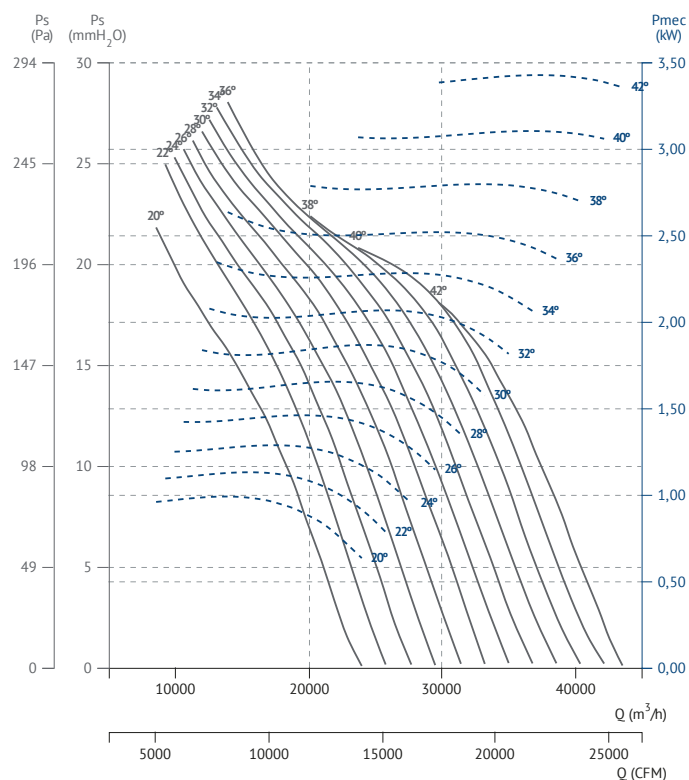

**HBF 100 T6 (A3:8) F400**

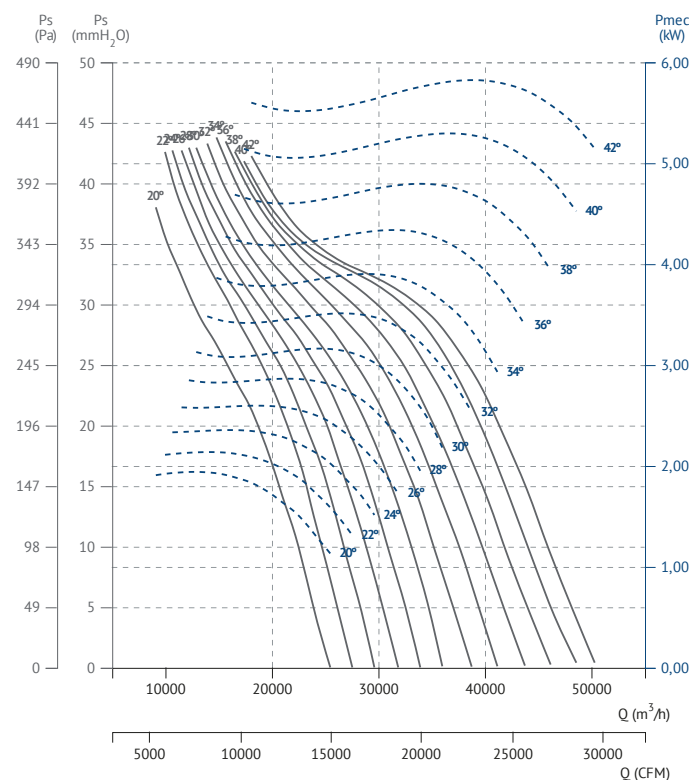





**HBF 112 T4 (A3:8) F400**

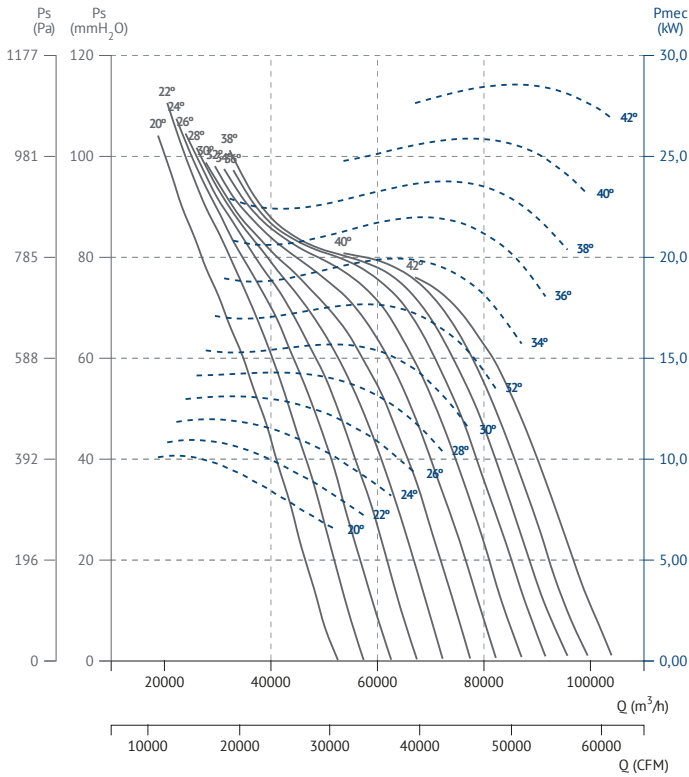

**HBF 112 T4 (A3:4) F400**

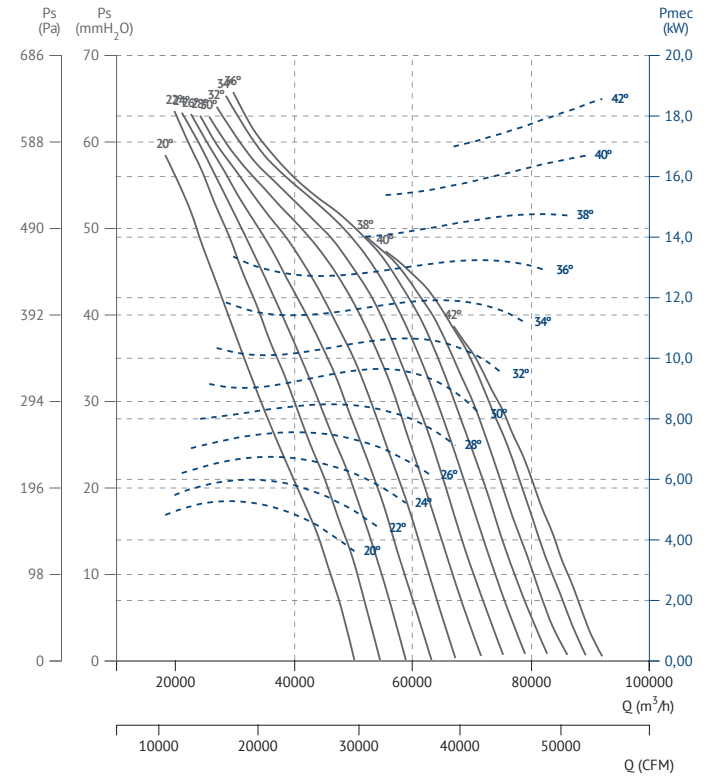

**HBF 112 T6 (A3:4) F400**

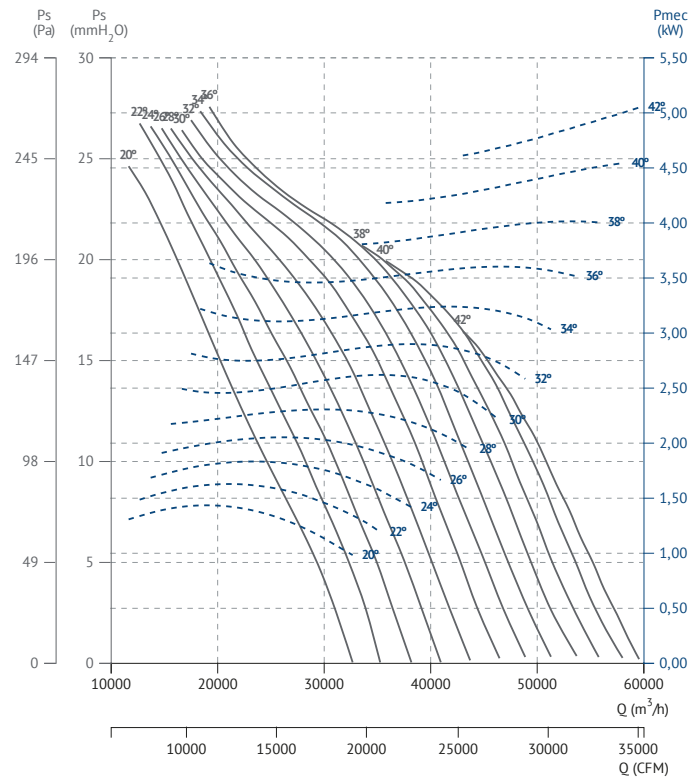

**HBF 112 T6 (A3:8) F400**

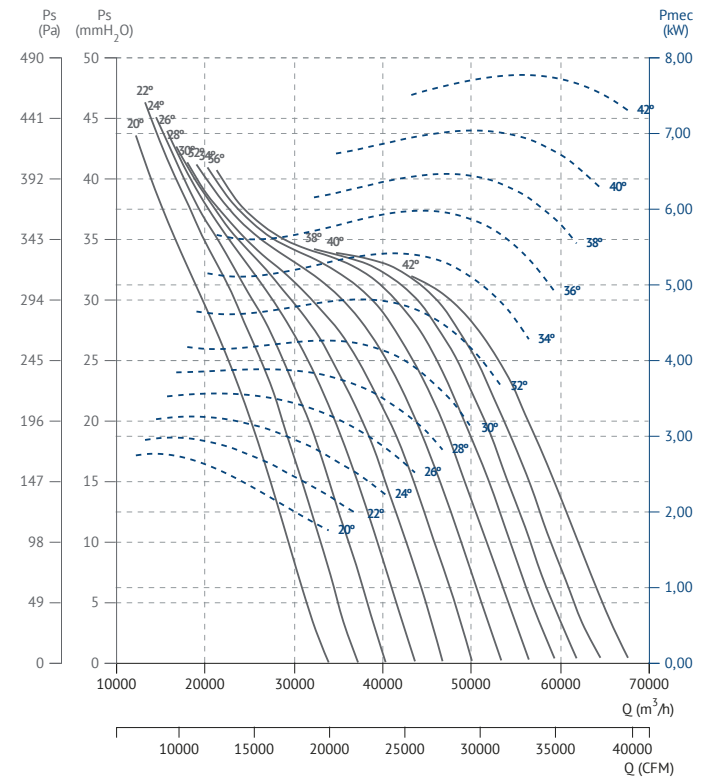



**HBF 125 T4 (A3:4) F400**

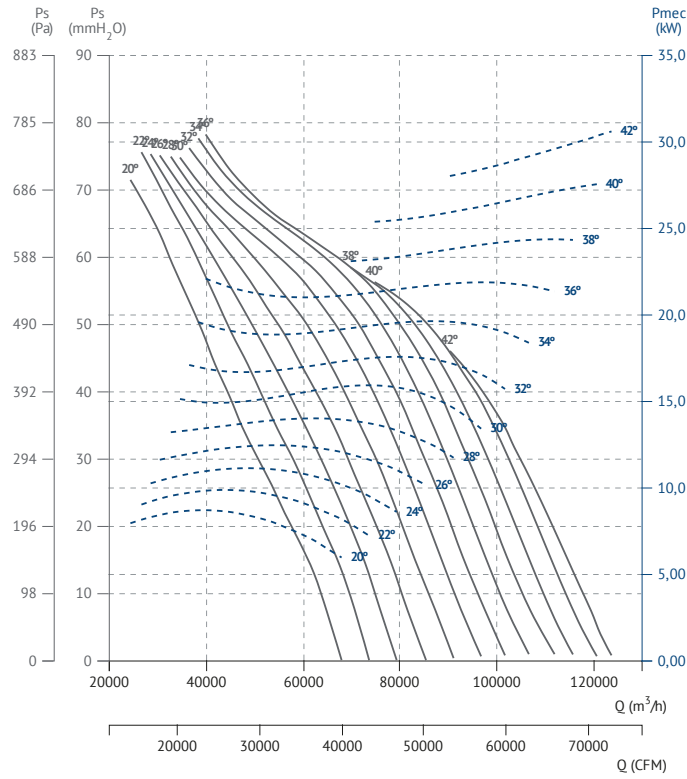

**HBF 125 T4 (A3:8) F400**

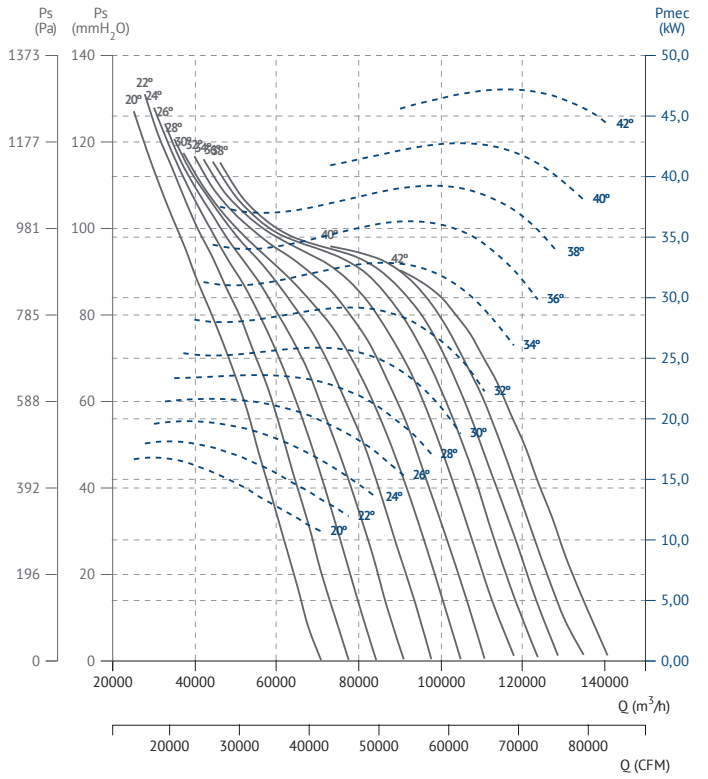

**HBF 125 T6 (A3:4) F400**

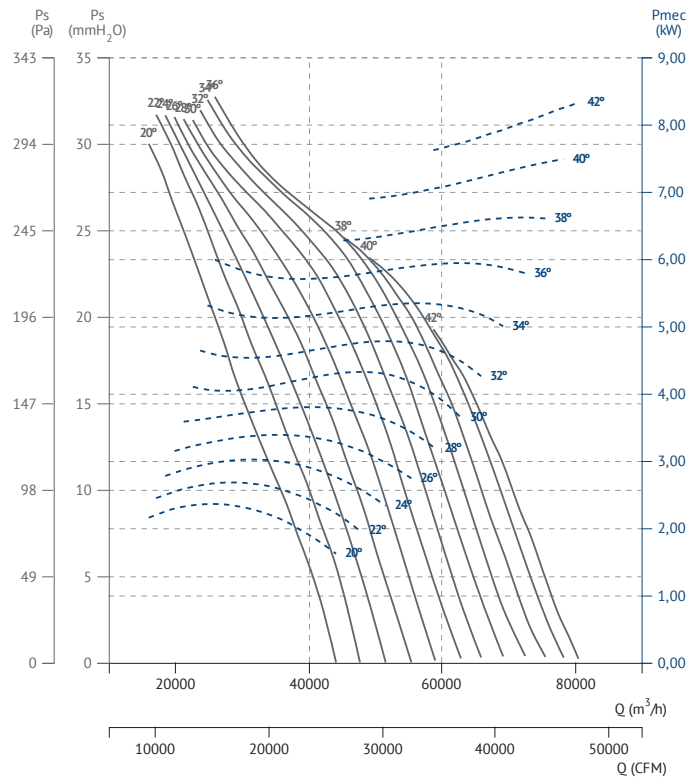

**HBF 125 T6 (A3:8) F400**

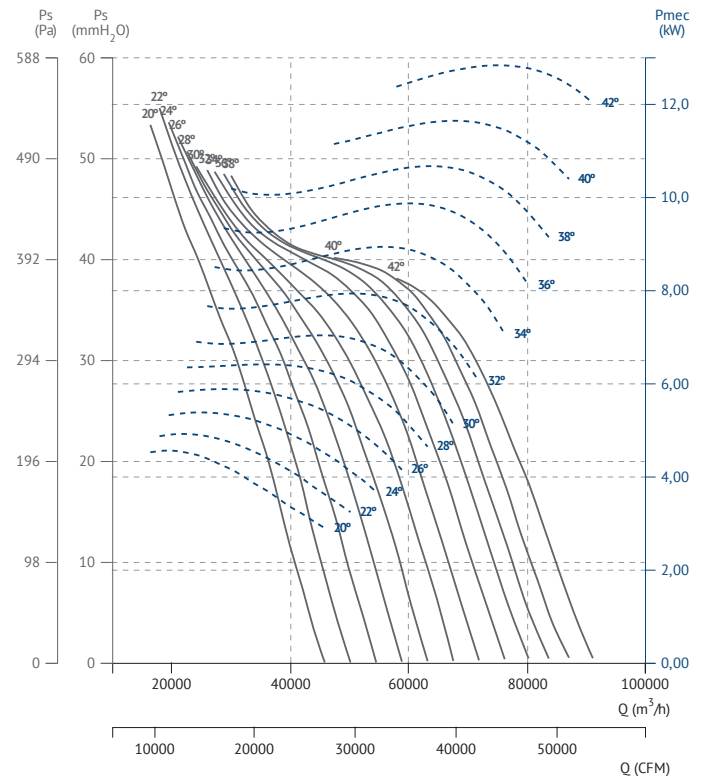

# HBF F300/ HBFX

Axial fan F300

Ventilador helicoidal F300



### MANUFACTURING FEATURES

- Axial fan with circular reinforced frame.
- Modular motor-impeller assembly.
- Impeller in aluminum injection with reinforced body. Protected against corrosion by powder coating of polyester resin.
- HBFX with protection ring made of aluminium.
- Standard asynchronous squirrel cage motor with IP-55 protection and Class H insulation certified 300°C/2h. Standard voltages 230/400V 50Hz in three phase motors up to 3kW and 400/690V 50Hz for higher powers. IE3 efficiency motor from 0,75kW up to 45kW in single speed.

### APPLICATIONS

- Designed for wall or duct installation, they are suitable for:
- Smoke emergency exhaust with motor inside the hazardous area.
  - Maximum working temperature: 60°C.

### UNDER REQUEST

- B Form impeller (air flow from impeller to motor). 5% additional cost.
- 100% reversible impeller. 5% additional cost.

### CARACTERÍSTICAS CONSTRUCTIVAS

- Ventilador helicoidal de marco redondo reforzado.
- Montaje modular del conjunto motor hélice.
- Hélice en inyección de aluminio con nervio intermedio. Protegidos contra la corrosión mediante recubrimiento en polvo de resina de poliéster.
- Anillo de protección en aluminio para HBFX.
- Motor asíncrono normalizado de jaula de ardilla con protección IP-55 y aislamiento clase H certificado 300°C/2h. Voltajes estándar 230/400V 50Hz para motores trifásicos hasta 3kW y 400/690V 50Hz para potencias superiores. Motor de eficiencia IE3 desde 0,75kW hasta 45kW de una velocidad.

### APLICACIONES

- Diseñados para montaje en pared o en conducto, son indicados para:
- Extracción de humo en caso de incendio estando el motor dentro de la zona de riesgo.
  - Temperatura máxima de trabajo en continuo: 60°C.

### BAJO DEMANDA

- Hélice impelente (sentido de aire hélice-motor). Incremento 5% sobre PVP.
- Hélice reversible 100%. Incremento 5% sobre PVP.



## ACCESSORIES / accesorios



### INT

Interruptor de corte  
Safety switch



### PC2

Rejilla de sobrepresión antirretorno  
Overpressure damper for facade



### INT 400

Interruptor selector de velocidad  
Speed selector switch



### SFC

Variador de velocidad frecuencial  
Frequency speed controller



### RPO

Rejilla protección impulsión  
Outlet protection guard



### RP1

Rejilla protección aspiración  
Inlet protection guard



### AC

Brida conexión  
Connection flange



### BA-400

Brida antivibratoria 400°C/2h  
Flexible flange 400°C/2H



### MC HB

Marco soporte cuadrado para HB  
Square mounting frame for HB



### JE 45

Junta elástica  
Flexible joint



### BAD

Brida de acoplamiento circular-circular  
Circular-Circular coupling flange

## THREE PHASE RANGE / serie trifásica

### 4 POLE / 4 polos

Model	Angle	Min. Rat. power kW	Max. Rat. power kW	Air flow m <sup>3</sup> /h	Sound dB (A) **	Weight Kg *	Connection diagram
HBF 45 T4 (A2:6) F300	20° - 45°	0,55	0,75	6.640	55	14	1
HBF 45 T4 (A2:9) F300	20° - 45°	0,55	0,75	7.000	55	14,50	1
HBF 50 T4 (A2:6) F300	20° - 45°	0,55	1,1	9.460	59	18,20	1
HBF 50 T4 (A2:9) F300	20° - 45°	0,55	1,1	9.150	59	18,70	1
HBF 56 T4 (A2:6) F300	20° - 45°	0,55	2,2	13.110	61	20,80	1
HBF 56 T4 (A2:9) F300	20° - 45°	0,55	2,2	13.810	61	21,30	1
HBF 63 T4 (A2:6) F300	20° - 45°	0,55	3	19.010	63	24,60	1
HBF 63 T4 (A2:9) F300	20° - 45°	0,55	3	20.610	63	25,20	1
HBF 71 T4 (A2:6) F300	20° - 45°	0,75	4	26.410	66	28,60	1
HBF 71 T4 (A2:9) F300	20° - 45°	0,75	4	25.700	68	29,20	1
HBF 80 T4 (A2:6) F300	20° - 45°	1,1	7,5	37.010	68	34	1

## Desenfumaje/ inmersos 400°C/2h, 300°C/2h, 200°C/2h

Homologación oficial APPLUS según norma EN 12101-3:2015



Model	Angle	Min. Rat. power kW	Max. Rat. power kW	Air flow m <sup>3</sup> /h	Sound dB (A) **	Weight Kg *	Connection diagram
HBF 80 T4 (A2:9) F300	20° - 45°	1,1	7,5	32.700	73	34,60	1
HBF 90 T4 (A6:3) F300	20° - 42°	3	15	48.510	76	55,30	1
HBF 90 T4 (A6:6) F300	20° - 42°	3	15	55.210	77	60,70	1
HBF 100 T4 (A6:3) F300	20° - 42°	5,5	22	66.010	77	67,60	1
HBF 100 T4 (A6:6) F300	20° - 42°	5,5	22	77.010	81	73,70	1
HBF 112 T4 (A6:3) F300	20° - 42°	5,5	37	87.010	79	76,50	1
HBF 112 T4 (A6:6) F300	20° - 42°	5,5	37	103.010	84	83,20	1
HBF 125 T4 (A6:3) F300	20° - 42°	7,5	45	121.010	84	86,40	1
HBF 125 T4 (A6:6) F300	20° - 42°	7,5	45	139.010	87	93,70	1

**6 POLE / 6 polos**

Model	Angle	Min. Rat. power kW	Max. Rat. power kW	Air flow m <sup>3</sup> /h	Sound dB (A) **	Weight Kg *	Connection diagram
HBF 45 T6 (A2:6) F300	20° - 45°	0,55	0,55	4.310	46	14	1
HBF 45 T6 (A2:9) F300	20° - 45°	0,55	0,55	4.540	46	14,50	1
HBF 50 T6 (A2:6) F300	20° - 45°	0,55	0,55	6.130	49	18,20	1
HBF 50 T6 (A2:9) F300	20° - 45°	0,55	0,55	6.550	49	18,70	1
HBF 56 T6 (A2:6) F300	20° - 45°	0,55	0,55	8.480	51	20,80	1
HBF 56 T6 (A2:9) F300	20° - 45°	0,55	0,55	8.970	51	21,30	1
HBF 63 T6 (A2:6) F300	20° - 45°	0,55	0,75	12.310	54	24,60	1
HBF 63 T6 (A2:9) F300	20° - 45°	0,55	0,75	13.310	54	25,20	1
HBF 71 T6 (A2:6) F300	20° - 45°	0,55	1,1	17.110	57	28,60	1
HBF 71 T6 (A2:9) F300	20° - 45°	0,55	1,1	18.610	59	29,20	1
HBF 80 T6 (A2:6) F300	20° - 45°	0,55	2,2	24.010	58	34	1
HBF 80 T6 (A2:9) F300	20° - 45°	0,55	2,2	25.710	64	34,60	1
HBF 90 T6 (A6:3) F300	20° - 42°	0,75	4	31.410	66	55,30	1
HBF 90 T6 (A6:6) F300	20° - 42°	0,75	4	35.810	67	60,70	1
HBF 100 T6 (A6:3) F300	20° - 42°	3	7,5	42.710	67	67,60	1
HBF 100 T6 (A6:6) F300	20° - 42°	3	7,5	49.910	71	73,70	1
HBF 112 T6 (A6:3) F300	20° - 42°	3	11	56.410	69	76,50	1
HBF 112 T6 (A6:6) F300	20° - 42°	3	11	66.810	74	83,20	1
HBF 125 T6 (A6:3) F300	20° - 42°	3	22	78.110	74	86,40	1
HBF 125 T6 (A6:6) F300	20° - 42°	3	22	89.910	78	93,70	1

**THREE PHASE RANGE 2 SPEEDS / serie trifásica 2 velocidades**
**4/8 POLE / 4/8 polos**

Model	Angle	Min. Rat. power kW	Max. Rat. power kW	Air flow m <sup>3</sup> /h	Sound dB (A) **	Weight Kg *	Connection diagram
HBF 45 T4/T8 (A2:6) F300	20° - 45°	0,6	0,8	6.640	55	14	2
HBF 45 T4/T8 (A2:9) F300	20° - 45°	0,6	0,8	7.000	55	14,5	2
HBF 50 T4/T8 (A2:6) F300	20° - 45°	0,6	1,2	9.460	59	18,2	2
HBF 50 T4/T8 (A2:9) F300	20° - 45°	0,6	1,2	10.110	59	18,7	2
HBF 56 T4/T8 (A2:6) F300	20° - 45°	0,6	2,2	13.100	61	20,8	2
HBF 56 T4/T8 (A2:9) F300	20° - 45°	0,6	2,2	13.810	61	21,3	2
HBF 63 T4/T8 (A2:6) F300	20° - 45°	0,6	2,8	19.010	63	24,6	2
HBF 63 T4/T8 (A2:9) F300	20° - 45°	0,6	2,8	20.610	63	25,2	2
HBF 71 T4/T8 (A2:6) F300	20° - 45°	0,8	3,8	26.410	66	28,6	2
HBF 71 T4/T8 (A2:9) F300	20° - 45°	0,8	3,8	28.710	68	29,2	2
HBF 80 T4/T8 (A2:6) F300	20° - 45°	1,2	7,5	37.010	68	34	2
HBF 80 T4/T8 (A2:9) F300	20° - 45°	1,2	7,5	39.610	73	34,6	2
HBF 90 T4/T8 (A6:3) F300	20° - 42°	2,8	14	48.350	76	55,3	2
HBF 90 T4/T8 (A6:6) F300	20° - 42°	2,8	14	55.210	77	60,7	2
HBF 100 T4/T8 (A6:3) F300	20° - 42°	3,8	28	65.950	77	67,6	2
HBF 100 T4/T8 (A6:6) F300	20° - 42°	3,8	28	77.010	81	73,7	2
HBF 112 T4/T8 (A6:3) F300	20° - 42°	3,8	44	86.990	79	76,5	2
HBF 112 T4/T8 (A6:6) F300	20° - 42°	3,8	44	103.010	84	83,2	2
HBF 125 T4/T8 (A6:3) F300	20° - 42°	5	44	120.810	84	86,4	2
HBF 125 T4/T8 (A6:6) F300	20° - 42°	5	44	139.010	87	93,7	2

\*\* Total sound pressure level at the point of maximum flow measured in dB(A) in the suction measured in free field at a distance of 6m from the source.

\*\* Nivel de presión sonora total en el punto de caudal máximo medido en dB(A) en la aspiración, medido en campo libre a una distancia de 6m de la fuente.

SMOKE EXHAUST/ INSIDE 400°C/2h, 300°C/2h, 200°C/2h

Desenfumaje/ inmersos 400°C/2h, 300°C/2h, 200°C/2h

Homologación oficial APPLUS según norma EN 12101-3:2015

**DIMENSIONS / dimensiones**

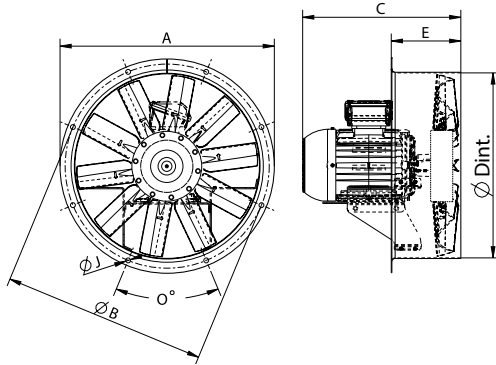

MODEL	ØA	ØB	ØD	E	ØI	O
HBF 45	525	500	452	170	12	8x45°
HBF 50	600	560	504	170	12	12x30°
HBF 56	646	620	559	175	12	12x30°
HBF 63	725	690	633	185	12	12x30°
HBF 71	802	770	715	190	12	16x22,5°
HBF 80	892	860	801	220	12	16x22,5°
HBF 90	1000	970	903,5	340	12	16x22,5°
HBF 100	1115	1070	1013	340	12	16x22,5°
HBF 112	1234	1190	1132	340	12	16x22,5°
HBF 125	1365	1320	1263	340	15	20x18°

C' max. Aprox. (Consult motor size table / Consultar tabla tamaño constructivo motor)

model	63	71	80	90S	90L	100L	112M	132S	132M	160M	160L	180M	180L	200	225
HBF 45	328	328	347	362	387	418	-	-	-	-	-	-	-	-	-
HBF 50	-	338	350	362	387	421	-	-	-	-	-	-	-	-	-
HBF 56	-	338	352	362	387	423	-	-	-	-	-	-	-	-	-
HBF 63	-	-	352	386	411	442	463	-	-	-	-	-	-	-	-
HBF 71	-	-	357	391	416	447	468	-	-	-	-	-	-	-	-
HBF 80	-	-	-	427	427	463	469	525	563	-	-	-	-	-	-
HBF 90	-	-	-	-	-	658	658	658	658	721	742	778	787	-	-
HBF 100	-	-	-	-	-	-	-	653	653	716	738	776	792	-	-
HBF 112	-	-	-	-	-	-	-	760	760	760	760	761	780	864	949
HBF 125	-	-	-	-	-	-	-	759	759	759	759	760	779	863	948

**MOTOR SIZE DEPENDING ON POWER (1 SPEED) / TAMAÑOS CONSTRUCTIVOS DE MOTORES SEGÚN POTENCIA (1 VELOCIDAD)**

	Kw																		
	0,075	0,09	0,12	0,18	0,25	0,37	0,55	0,75	1,1	1,5	2,2	3	4	5,5	7,5	11	15	18,5	22
M2-T2 (3000rpm)	-	56	56	63	63	71	71	80	80	90S	90L	100L	112M	132S	132S	160M	160M	160L	180M
M4-T4 (1500rpm)	56	56	63	63	71	71	80	80	90S	90L	100L	100L	112M	132S	132M	160M	160L	180M	180L
M6-T6 (1000rpm)	-	63	-	71	71	80	80	90S	90L	100L	112M	132S	132M	132M	160M	160L	180L	200L	200L
M8-T8 (750rpm)	-	71	71	80	80	90S	90L	100L	100L	112M	132S	132M	160M	160M	160L	180L	200L	225S	225M

**CONNECTION DIAGRAMS / esquema de conexiones**

**1 THREE PHASE MOTORS 1 SPEED / motores trifásicos 1 velocidad**

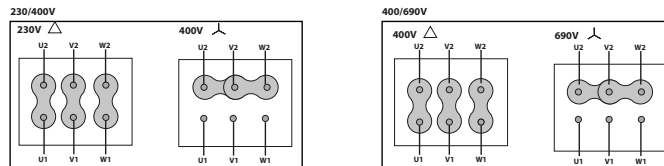

**2 400V DAHLANDER**

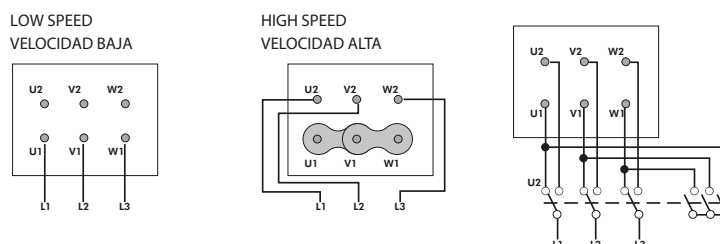



**CHARACTERISTIC CURVES / curvas características**

**HBF 45 T4 (A2:6) F300**

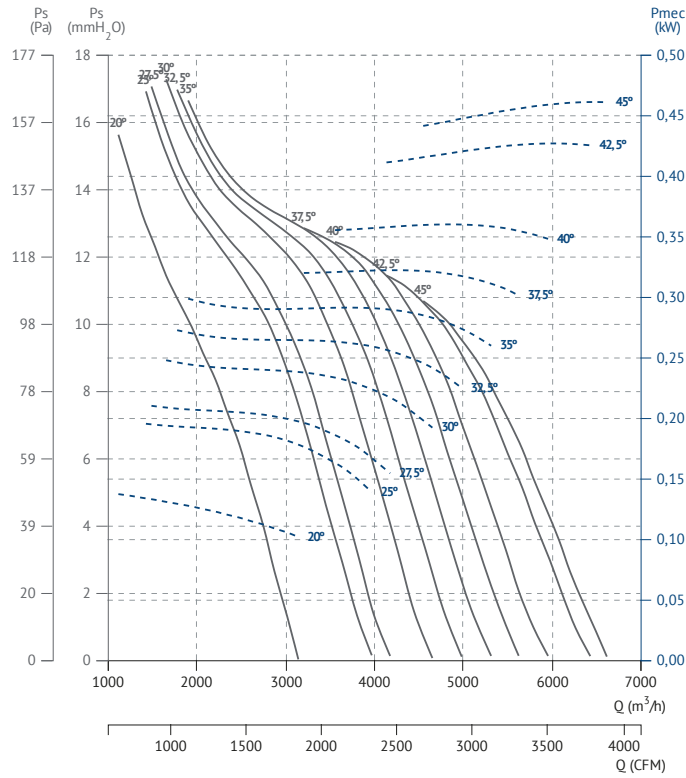

**HBF 45 T4 (A2:9) F300**

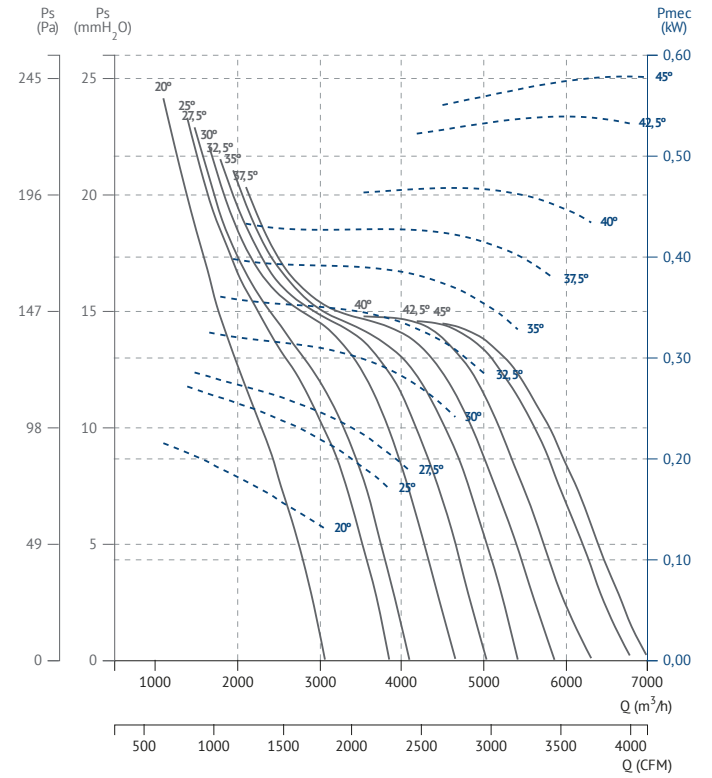

**HBF 45 T6 (A2:6) F300**

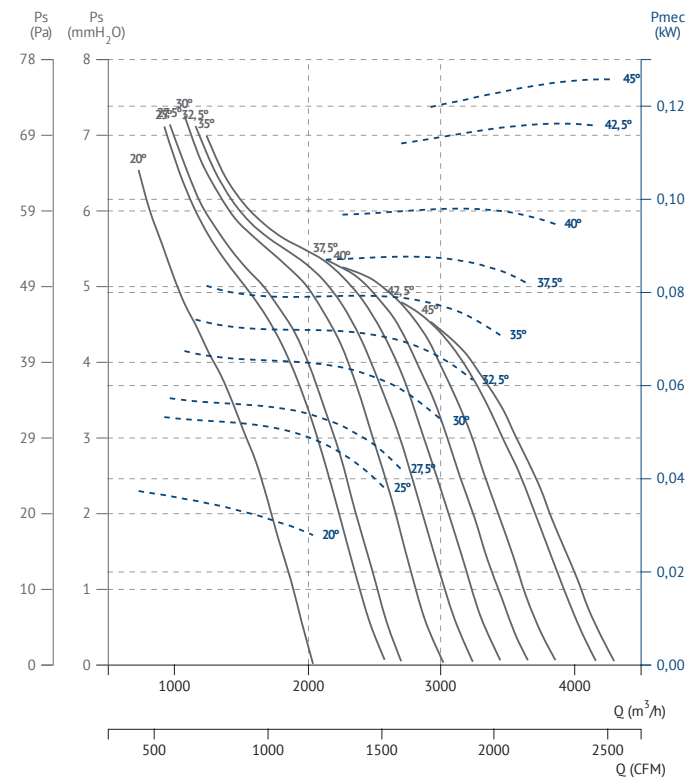

**HBF 45 T6 (A2:9) F300**

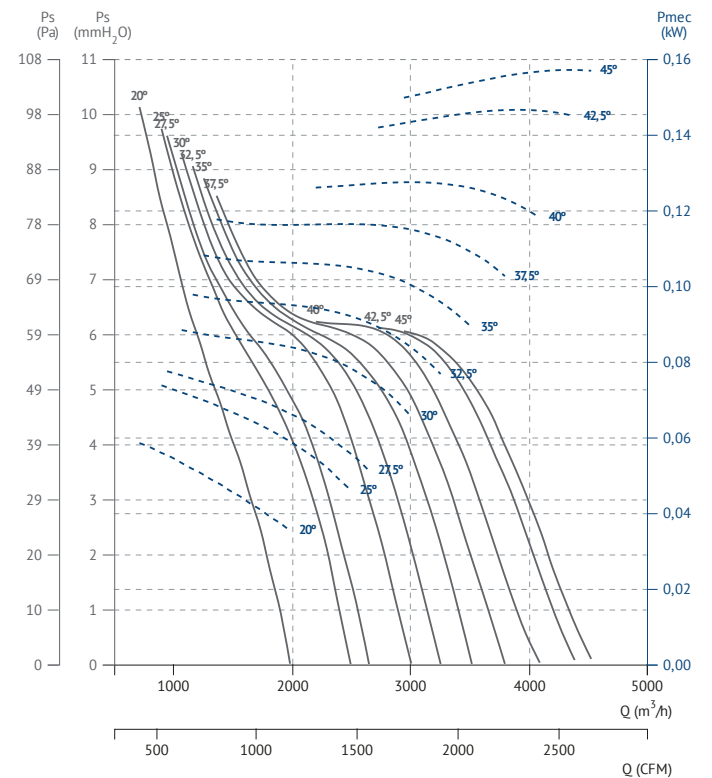



**HBF 50 T4 (A2:6) F300**

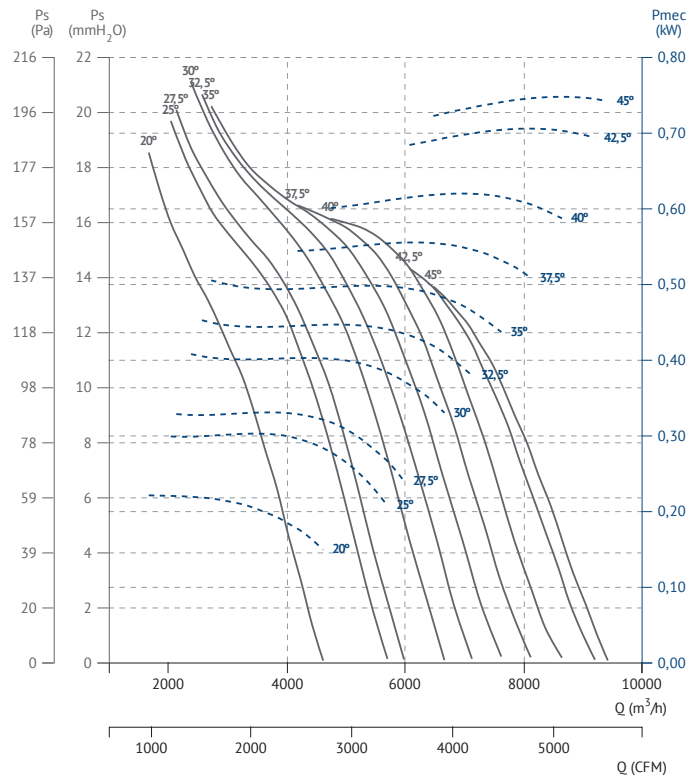

**HBF 50 T4 (A2:9) F300**

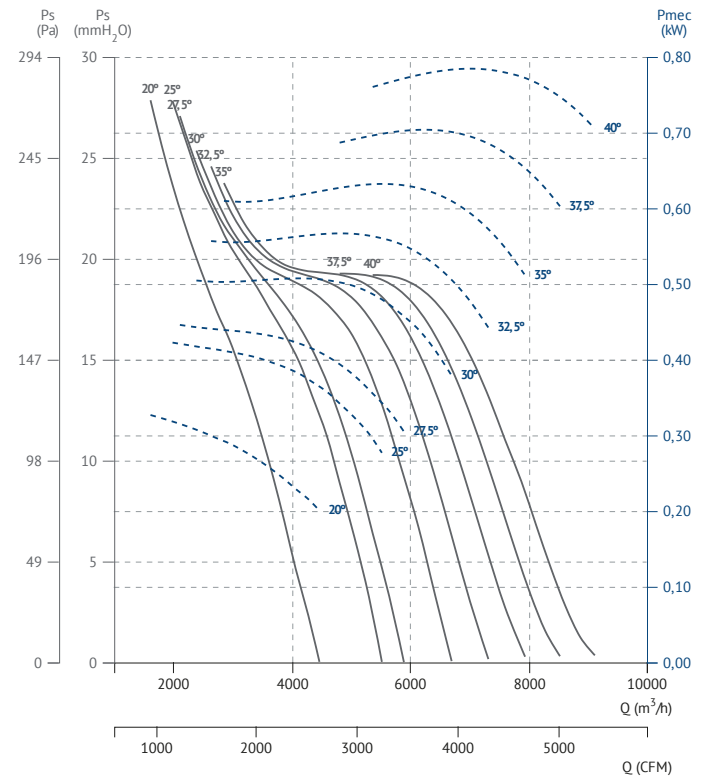

**HBF 50 T6 (A2:6) F300**

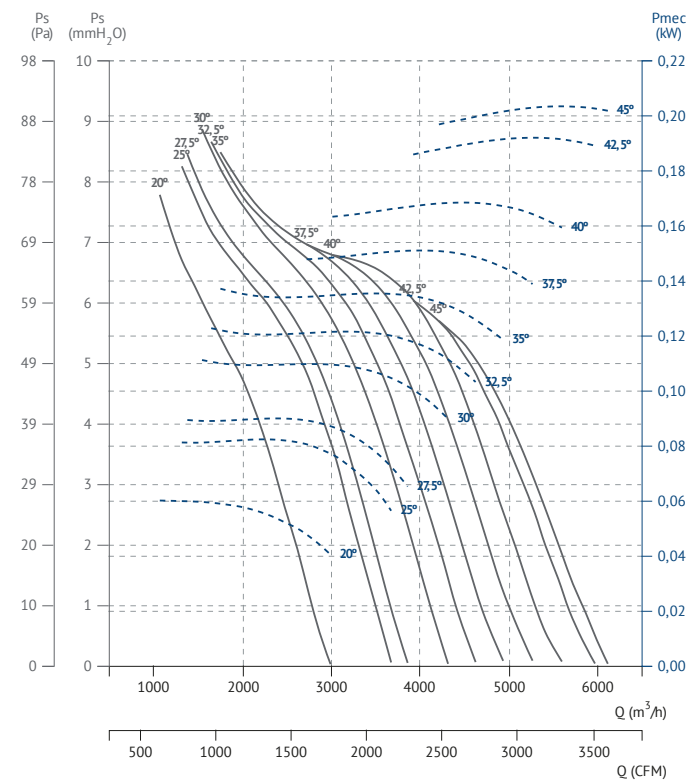

**HBF 50 T6 (A2:9) F300**

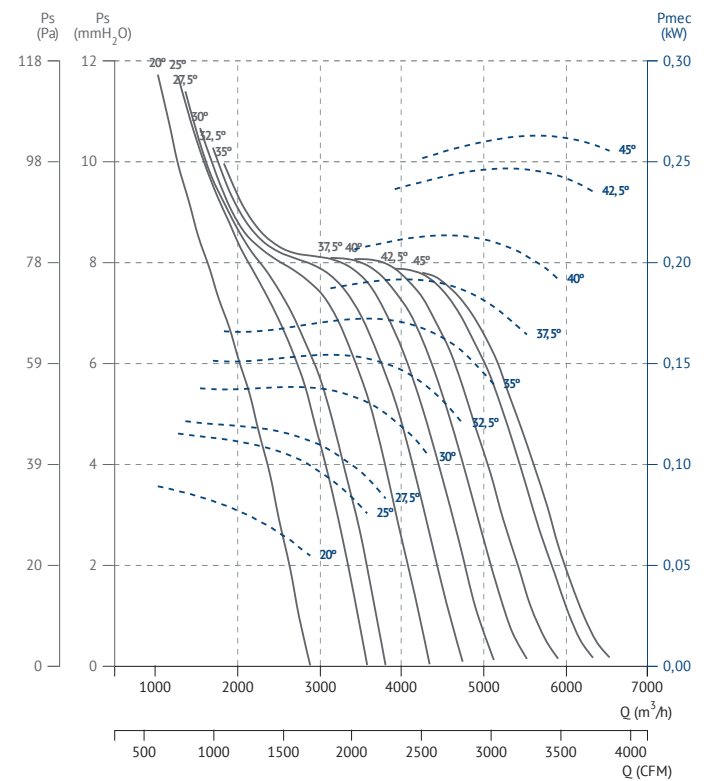



**HBF 56 T4 (A2:6) F300**

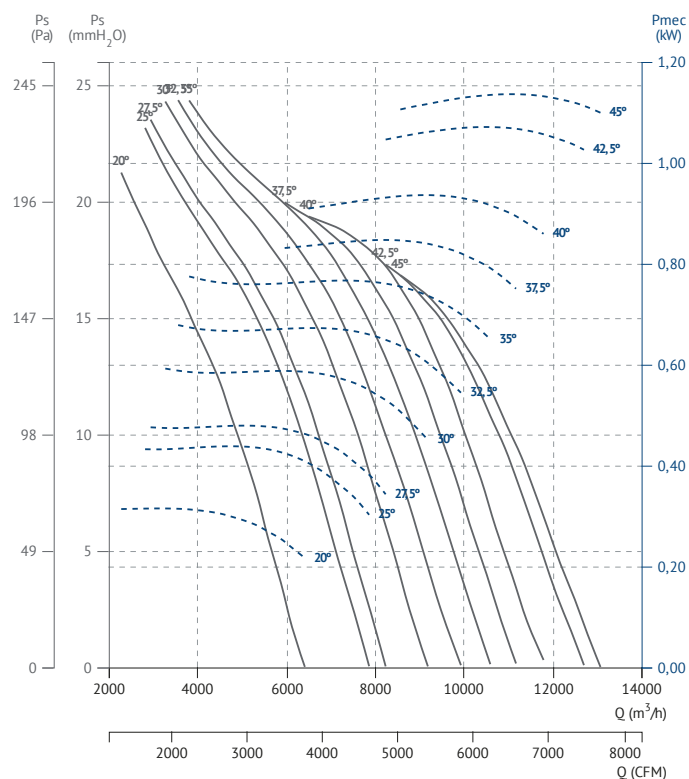

**HBF 56 T4 (A2:9) F300**

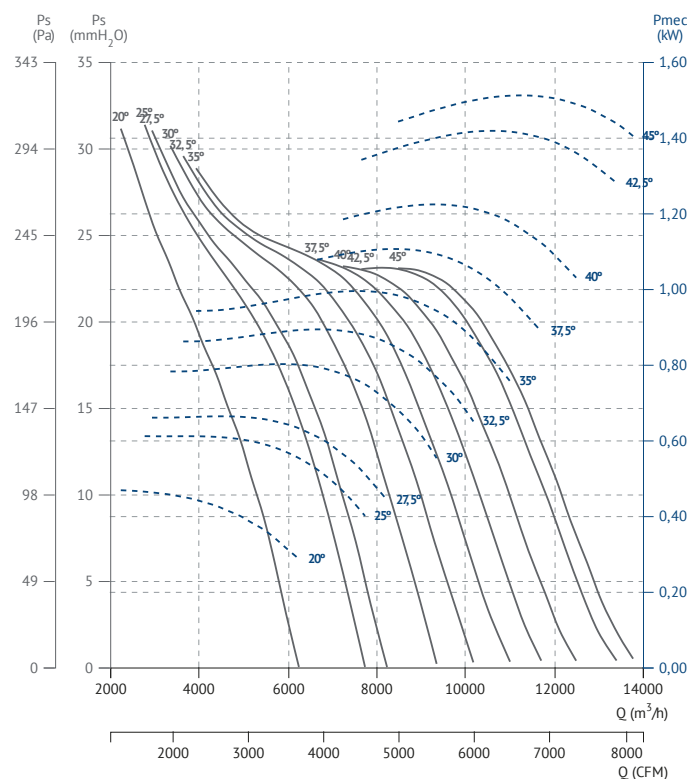

**HBF 56 T6 (A2:9) F300**

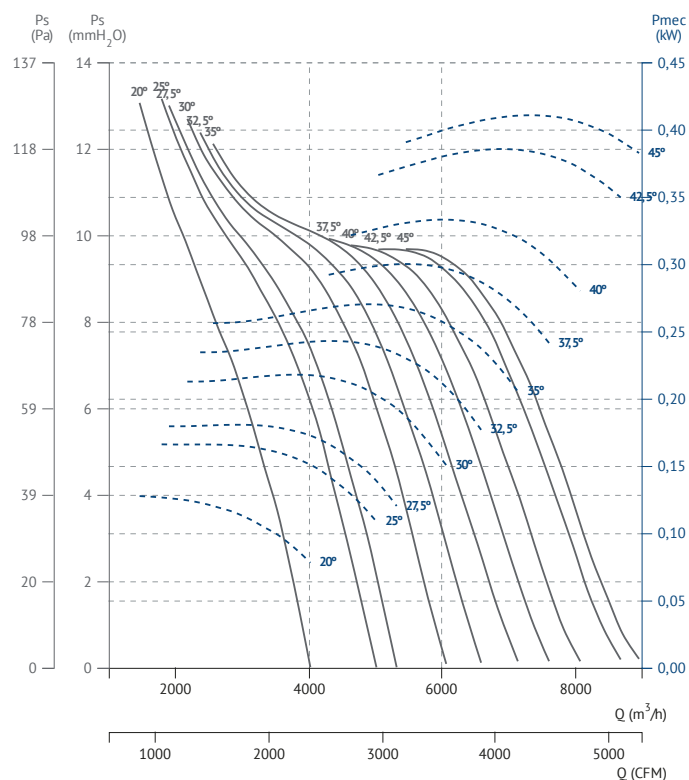

**HBF 56 T6 (A2:6) F300**

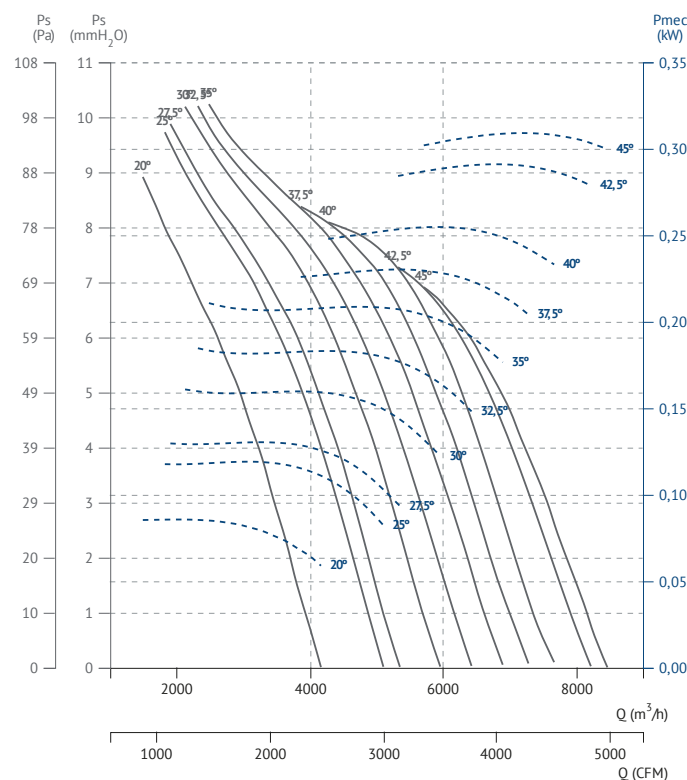



**HBF 63 T4 (A2:6) F300**

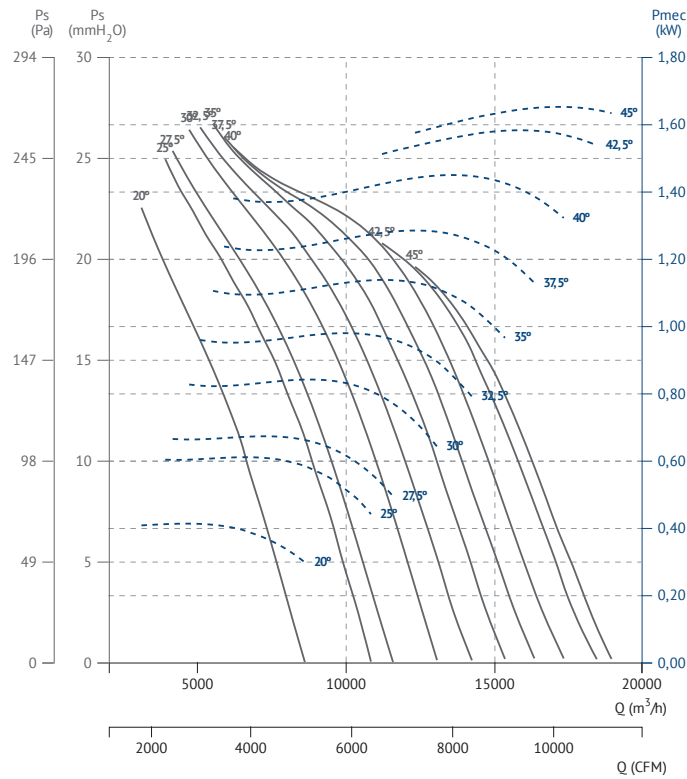

**HBF 63 T4 (A2:9) F300**

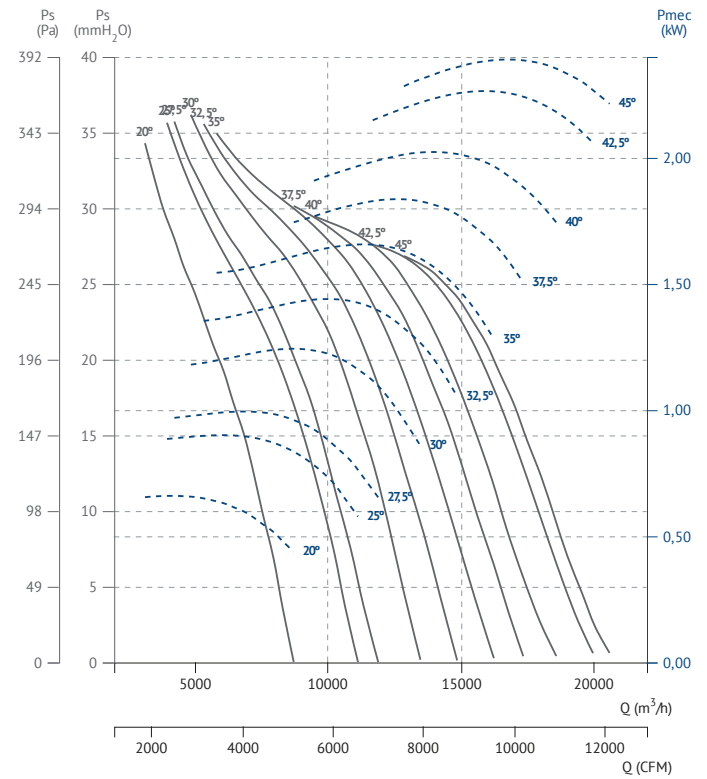

**HBF 63 T6 (A2:6) F300**

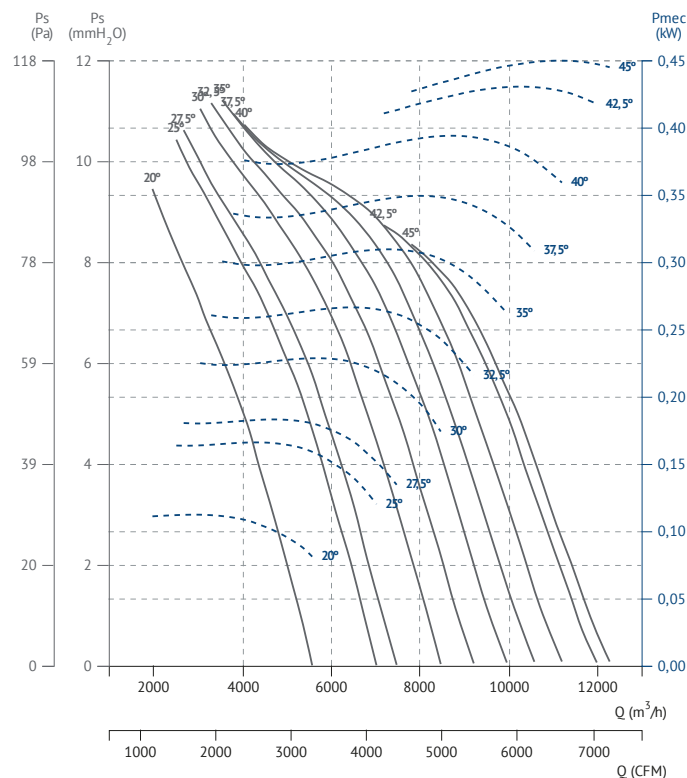

**HBF 63 T6 (A2:9) F300**

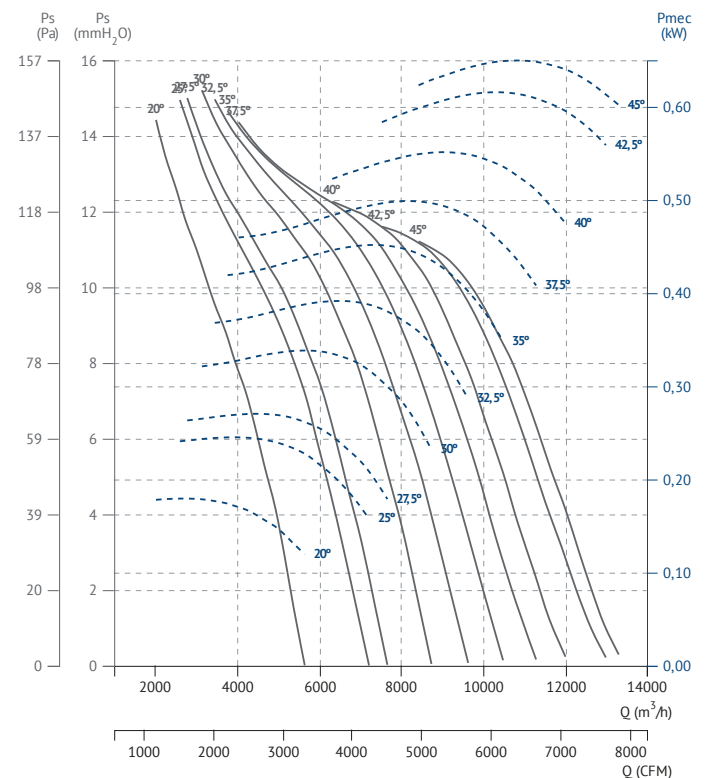



**HBF 71 T4 (A2:6) F300**

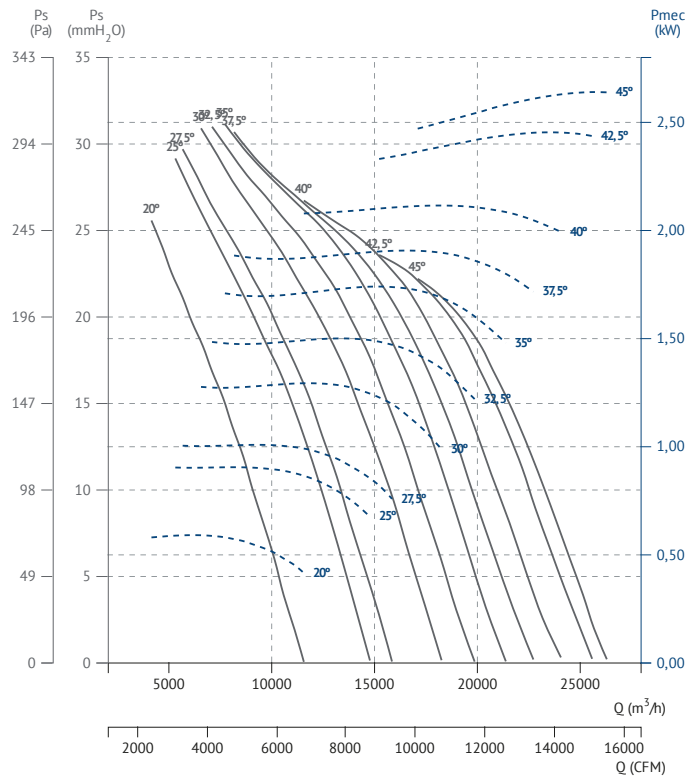

**HBF 71 T4 (A2:9) F300**

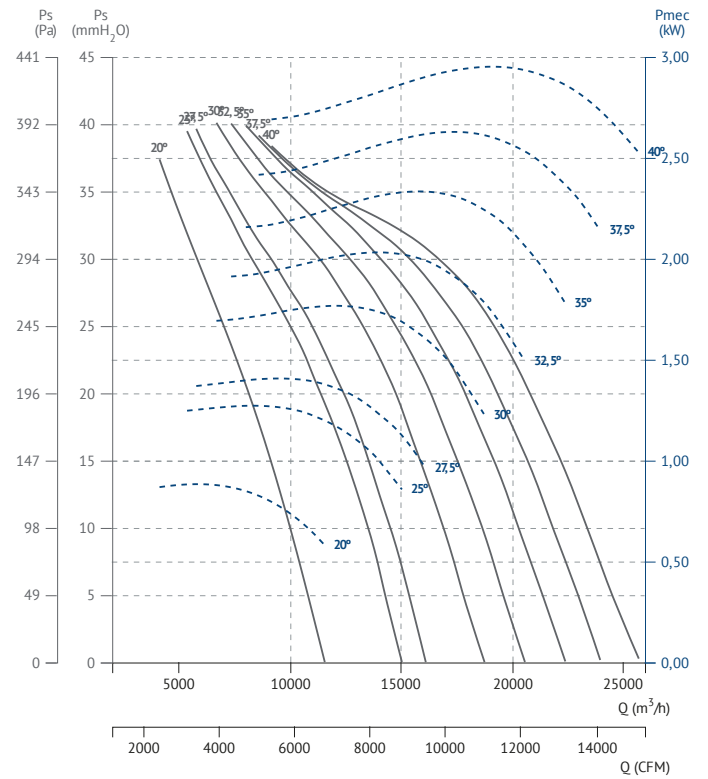

**HBF 71 T6 (A2:6) F300**

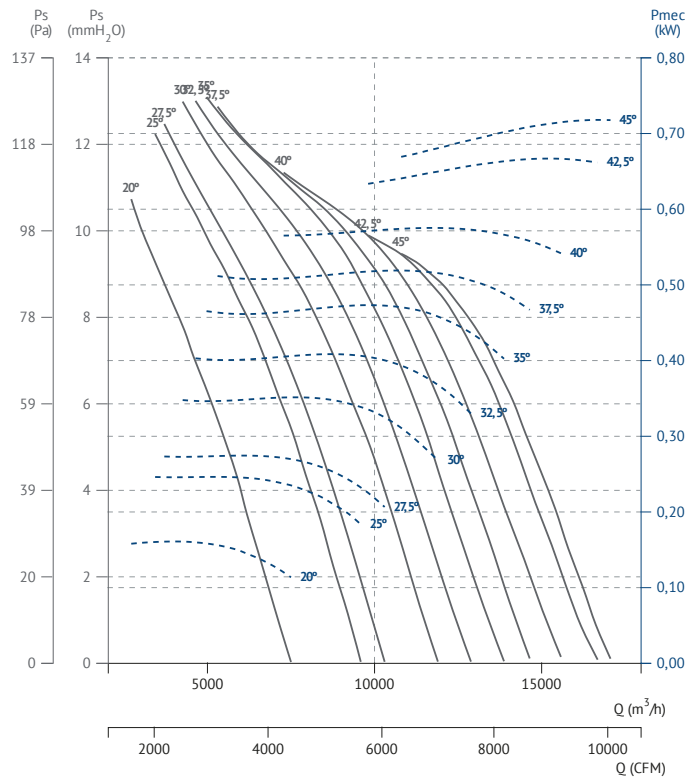

**HBF 71 T6 (A2:9) F300**

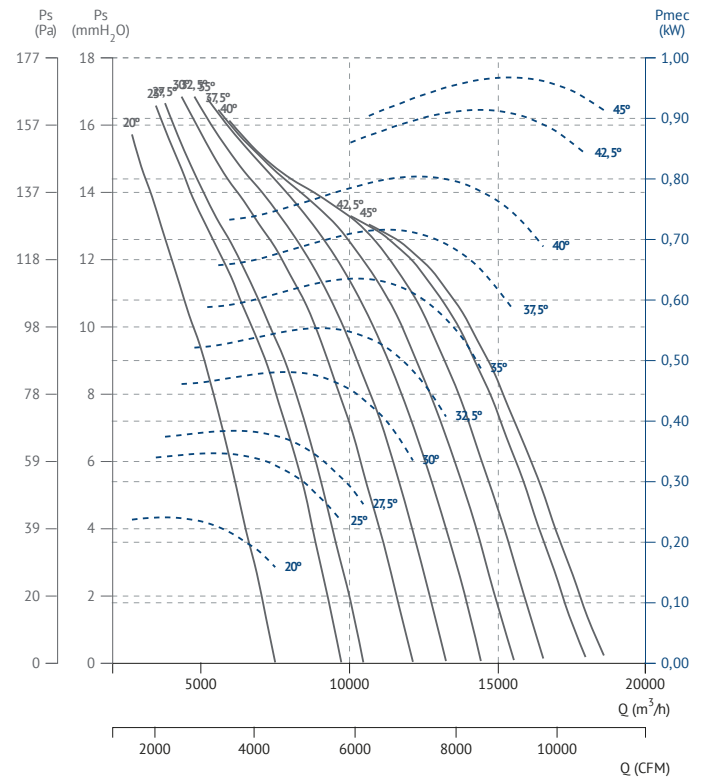



**HBF 80 T4 (A2:6) F300**

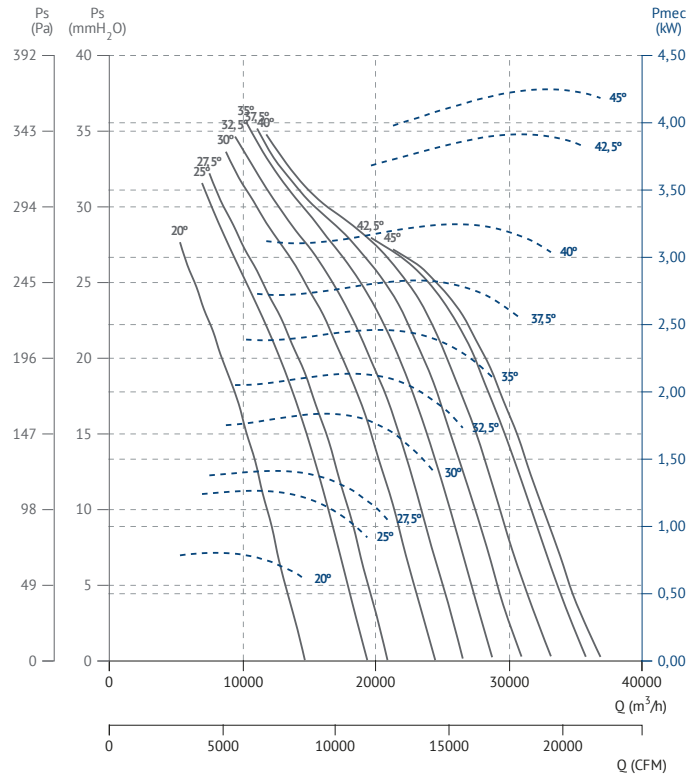

**HBF 80 T4 (A2:9) F300**

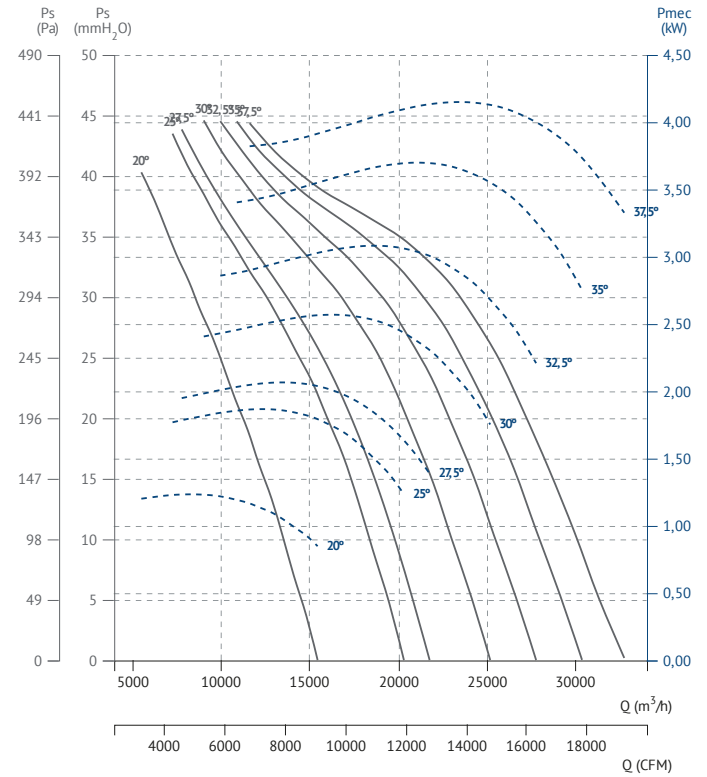

**HBF 80 T6 (A2:6) F300**

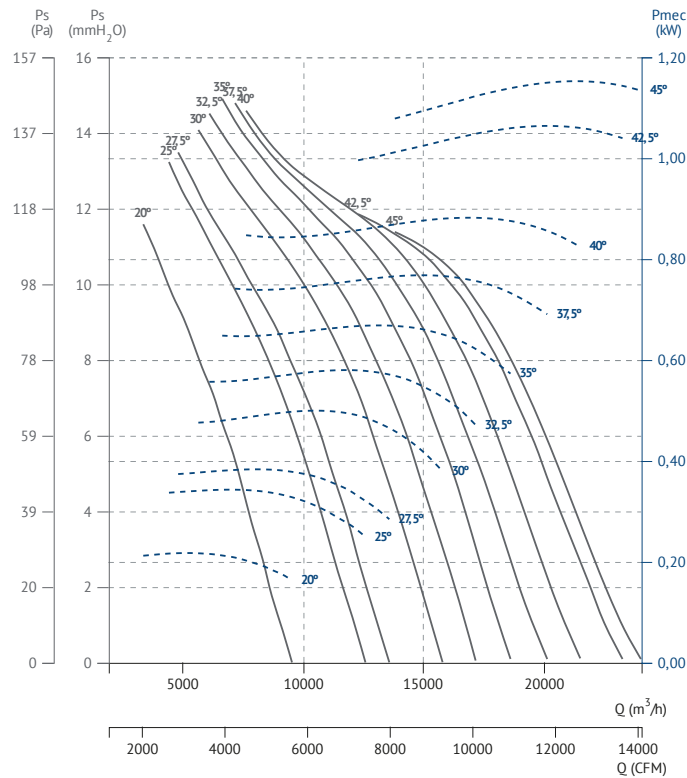

**HBF 80 T6 (A2:9) F300**

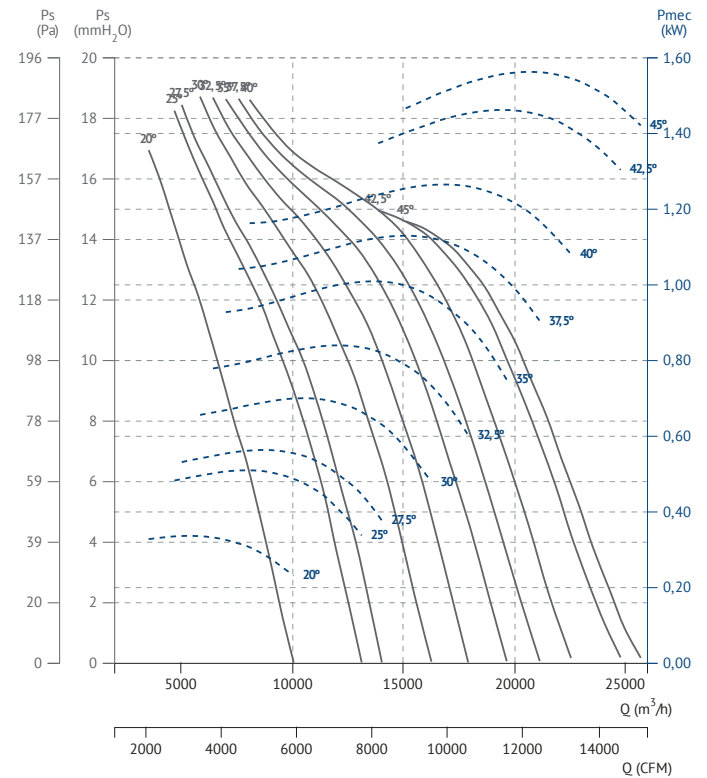



**HBF 90 T4 (A6:3) F300**

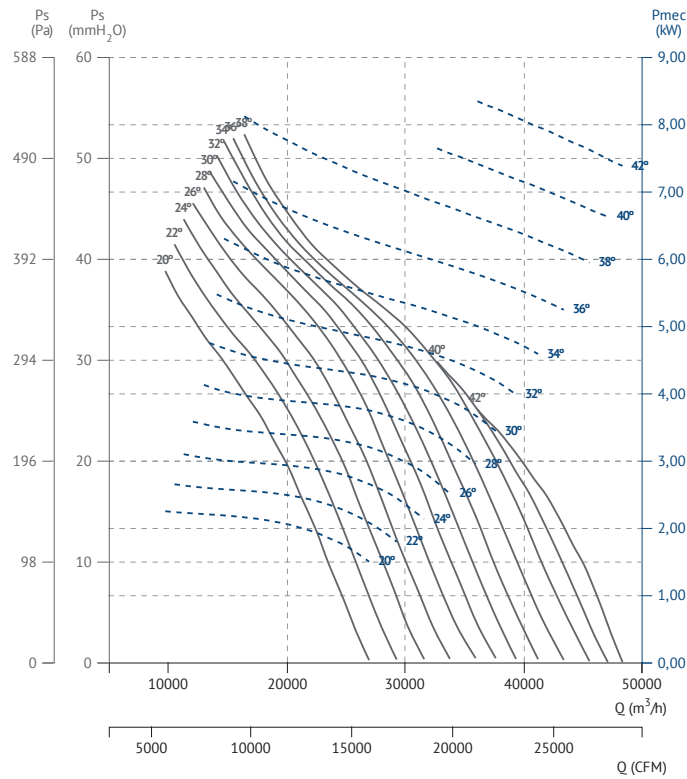

**HBF 90 T4 (A6:6) F300**

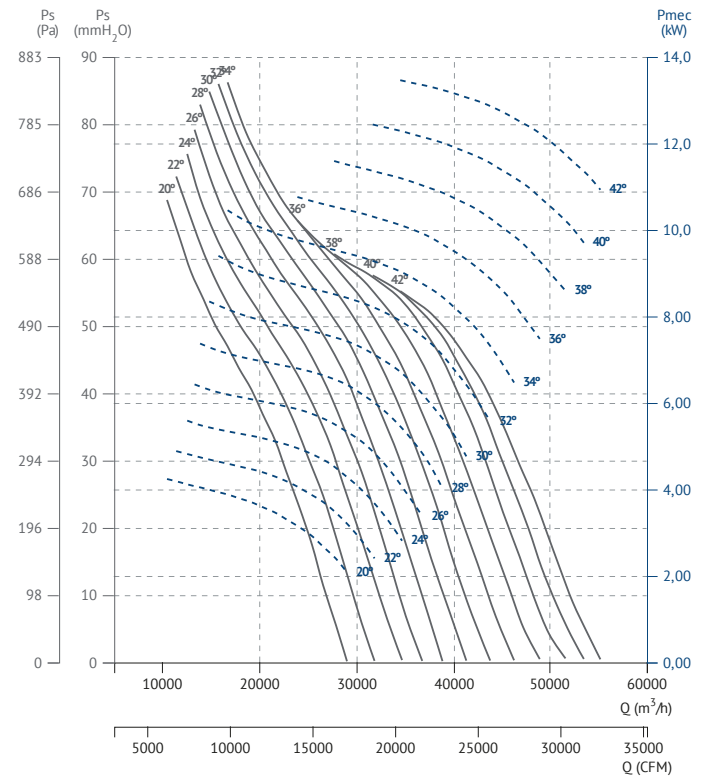

**HBF 90 T6 (A6:3) F300**

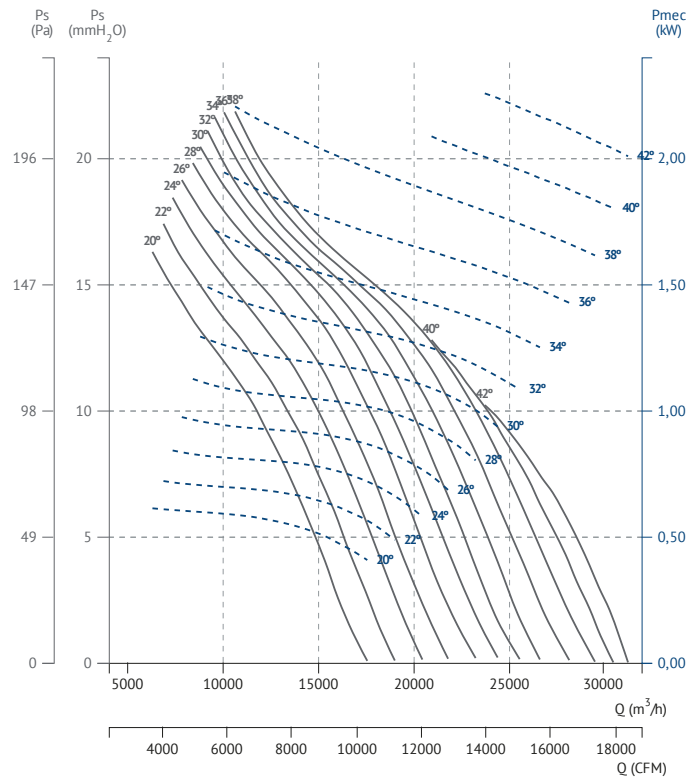

**HBF 90 T6 (A6:6) F300**

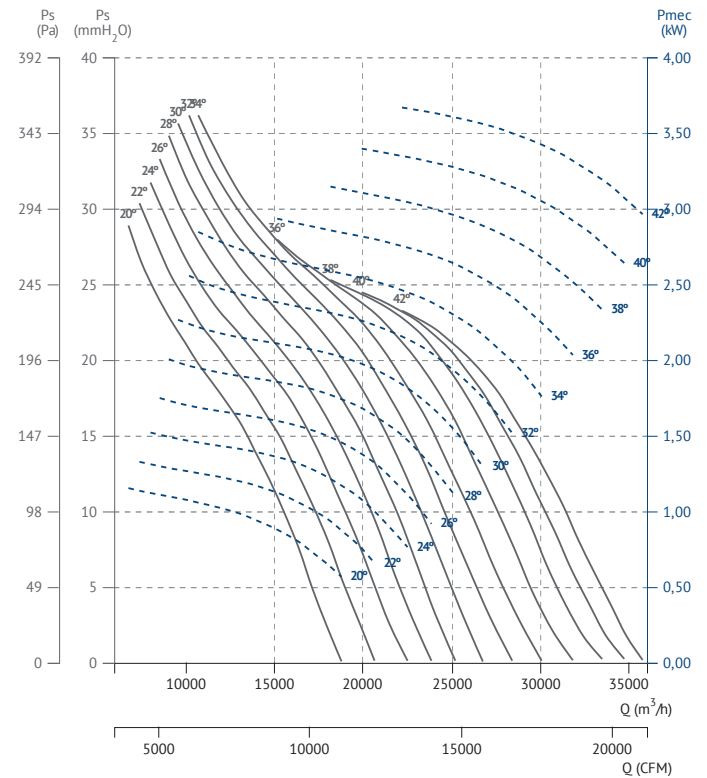



**HBF 100 T4 (A6:3) F300**

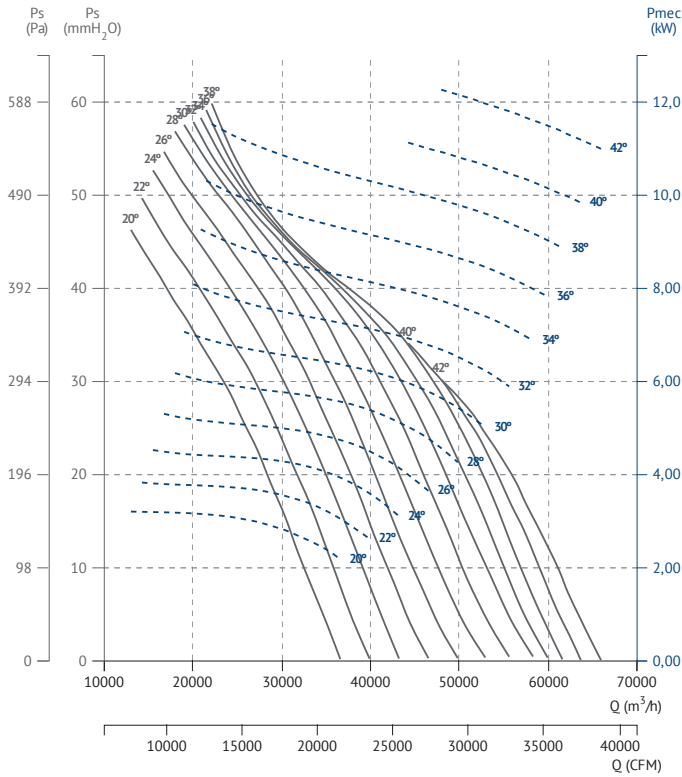

**HBF 100 T4 (A6:6) F300**

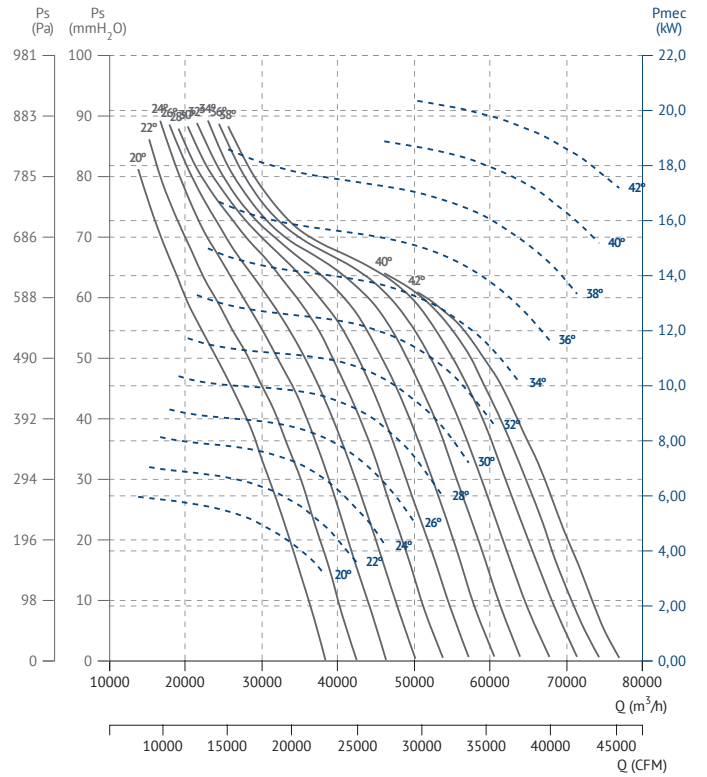

**HBF 100 T6 (A6:6) F300**

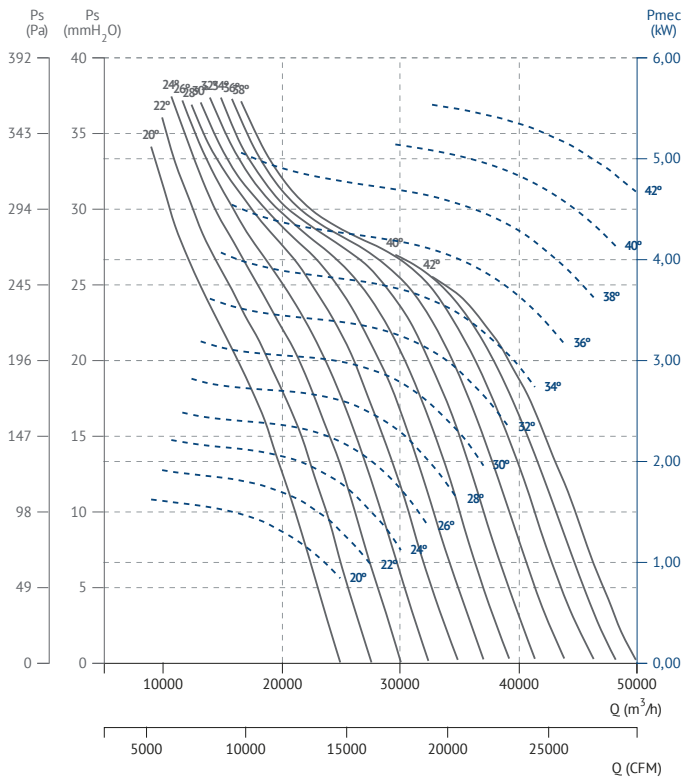

**HBF 100 T6 (A6:3) F300**

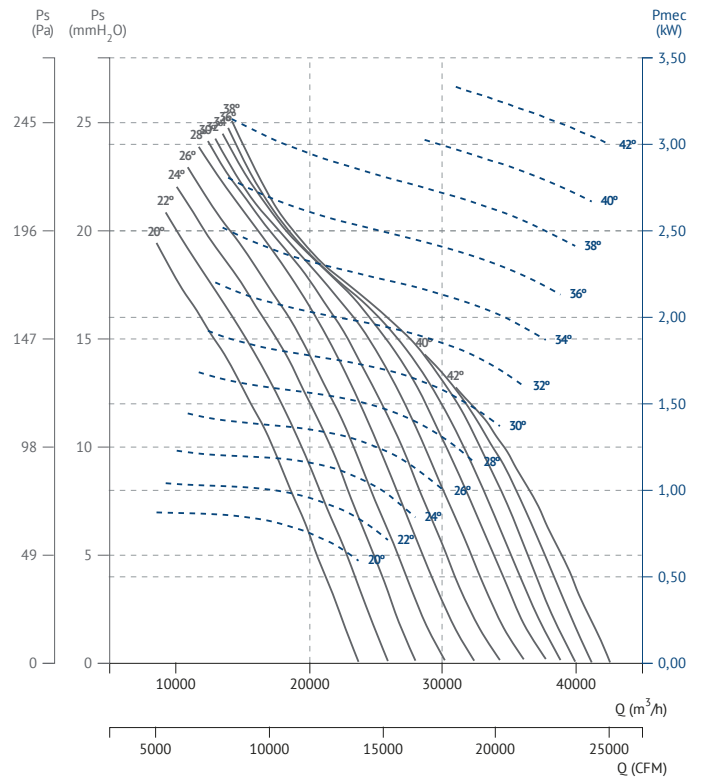



**HBF 112 T4 (A6:3) F300**

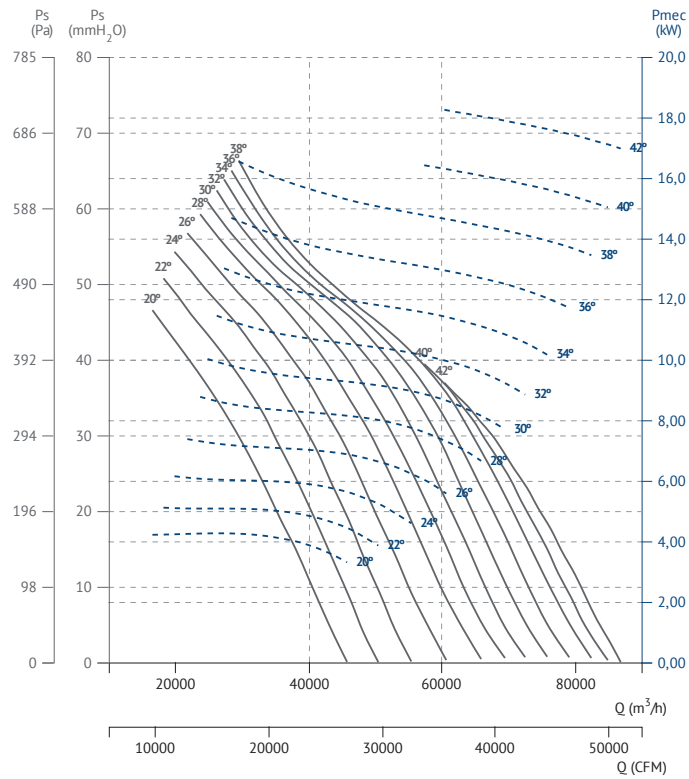

**HBF 112 T4 (A6:6) F300**

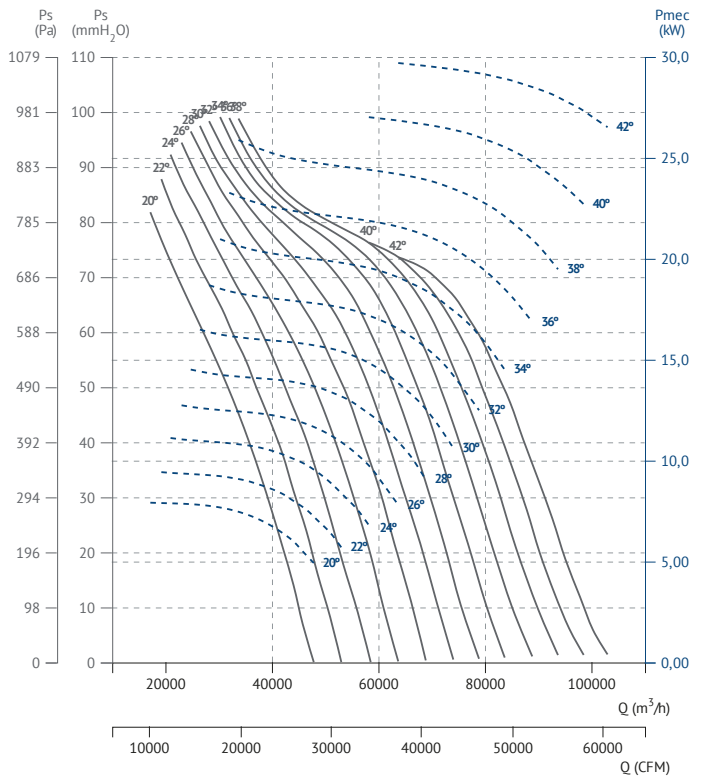

**HBF 112 T6 (A6:3) F300**

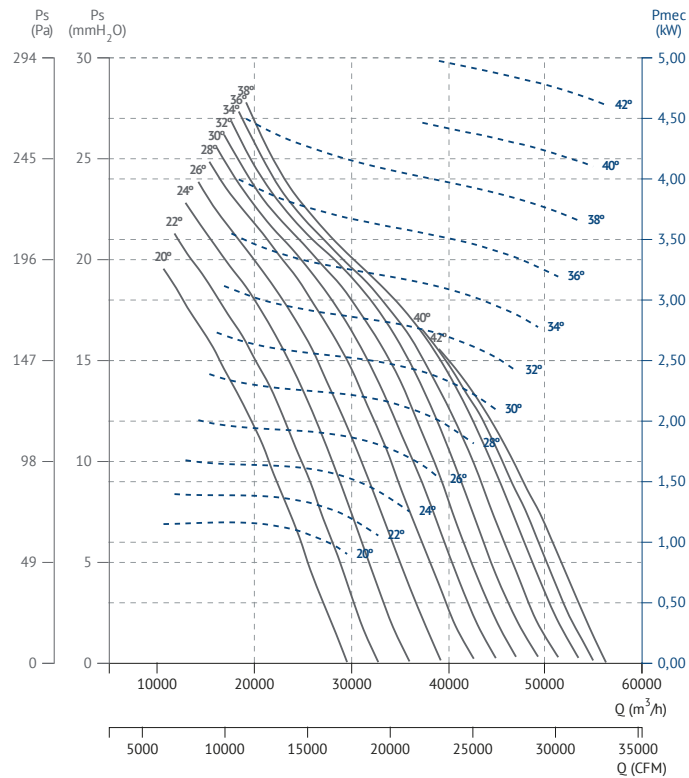

**HBF 112 T6 (A6:6) F300**

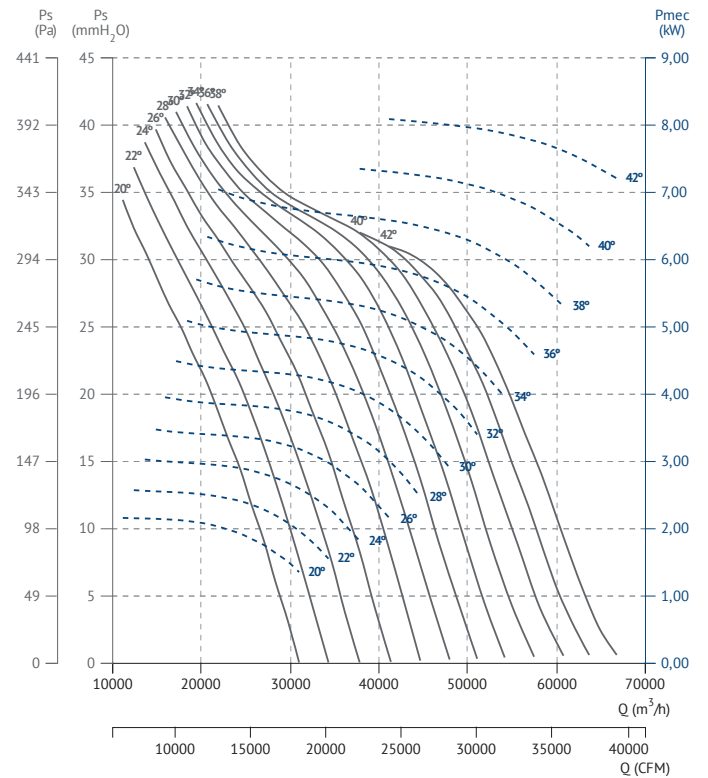



**HBF 125 T4 (A6:3) F300**

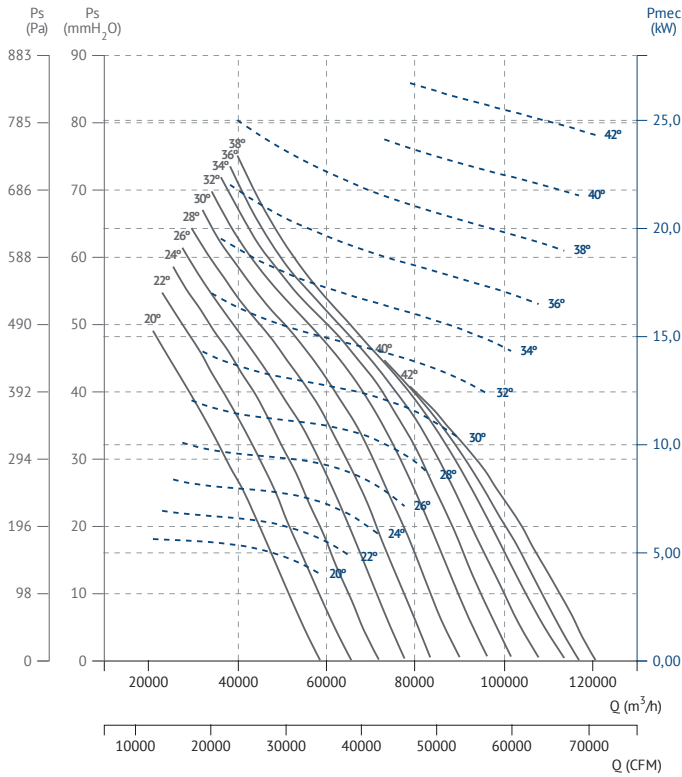

**HBF 125 T4 (A6:6) F300**

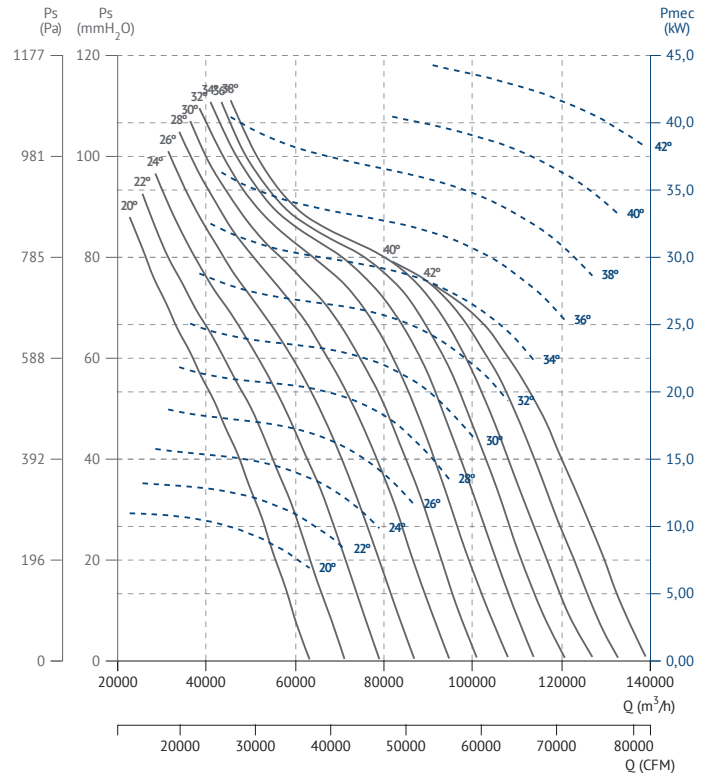

**HBF 125 T6 (A6:3) F300**

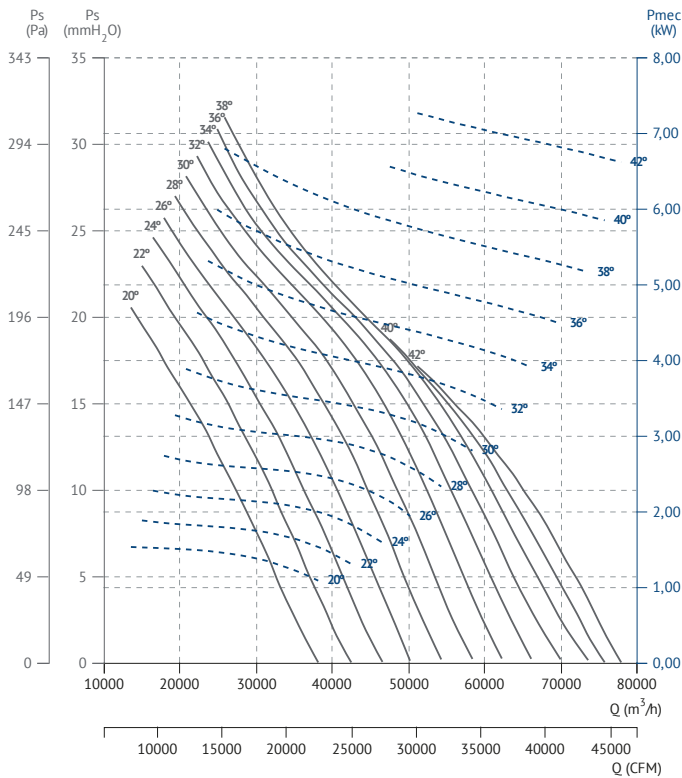

**HBF 125 T6 (A6:6) F300**

