



CENTRALIZED HEAT RECOVERY UNIT COMPACT SIZE

APPLICATION

Whole-house heat recovery unit, suitable for vertical installation. Can be installed in cupboard or narrow spaces thanks to its compact sizes.

SPECIFICATION

Outer fan casing manufactured from powder coated galvanised sheet steel providing long lasting and robust construction. The unit is finished in white RAL 9010.

Internal structure manufactured from EPP (expanded polypropylene) providing reduced sound emissions and maximised air tightness and thermal insulation.

EC external rotor motors fitted as standard for energy saving. Provided with integral thermal protection, mounted on sealed for life ball bearings.

Backward curved centrifugal impeller dynamically balanced and directly driven by the motor to provide a smooth airflow through the unit.

Highly efficient counterflow heat exchanger to maximise thermal recovery.

FEATURES & BENEFITS

Ease of installation: fixing brackets supplied to hang the unit easily on the wall.

Removable front panel for quick access to filters and heat exchanger.

G4 filters easy removable for cleaning. Remote F7 filter cassette on request.

Integral physical bypass for free cooling during the summer season: automatic operation in the ABP version, manual in the MBP version.

Automatic anti-frost protection to prevent frost building up on the intake side of the heat exchanger.

Two drainage holes to meet climate requirement.

Tested to the latest standards: units are tested in the TÜV Rheinland recognised laboratory at Aeruliga, meaning accurate, up to date information on electrical safety, performance and noise level that can be relied upon.

Designed and manufactured in accordance with EN60335-2-80 (Low Voltage Directive) and the EMC Directive (Electromagnetic Compatibility).

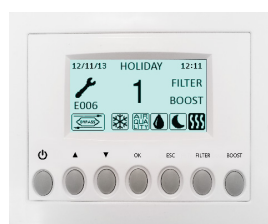

CTRL-DSP

VERSIONS

QR350 MBP

- One speed
- Two speed
- Variable speed with remote control CTRL-M
- Variable speed with remote home automation system (BMS) or ballast potentiometer
- 3 speed with remote control CTRL-S: bypass switch included.
- Manual bypass

QR350 ABP

The unit is supplied with a multi-function LCD display (CTRL-DSP) for automatic control and convenience, providing:

- 3 speeds setting (adjustable)
- Boost option
- Holiday mode
- Night mode: during night time the automatic operation via sensors is deactivated to prevent undesired speed rise and consequent noise increase.
- Automatic Bypass.
- Airflow balancing.
- Filter replacement and fan failure indicator.
- Working hour counter
- Setting saving and loading.
- Volt-free contacts for remote ambient sensors (SEN-HY, SEN-PIR, SEN-CO₂).
- Analogic input 1-10V for "slave" function if connected to BMS (home automation) system.
- Integral S/L terminal for boost from remote switch, i.e. light or dedicated switch.
- Connection to remote pre/post heating element.
- Connection to remote dehumidifying element.
- Possible change of orientation of the atmosphere spigots.

QR350

Example of a complete ventilation system

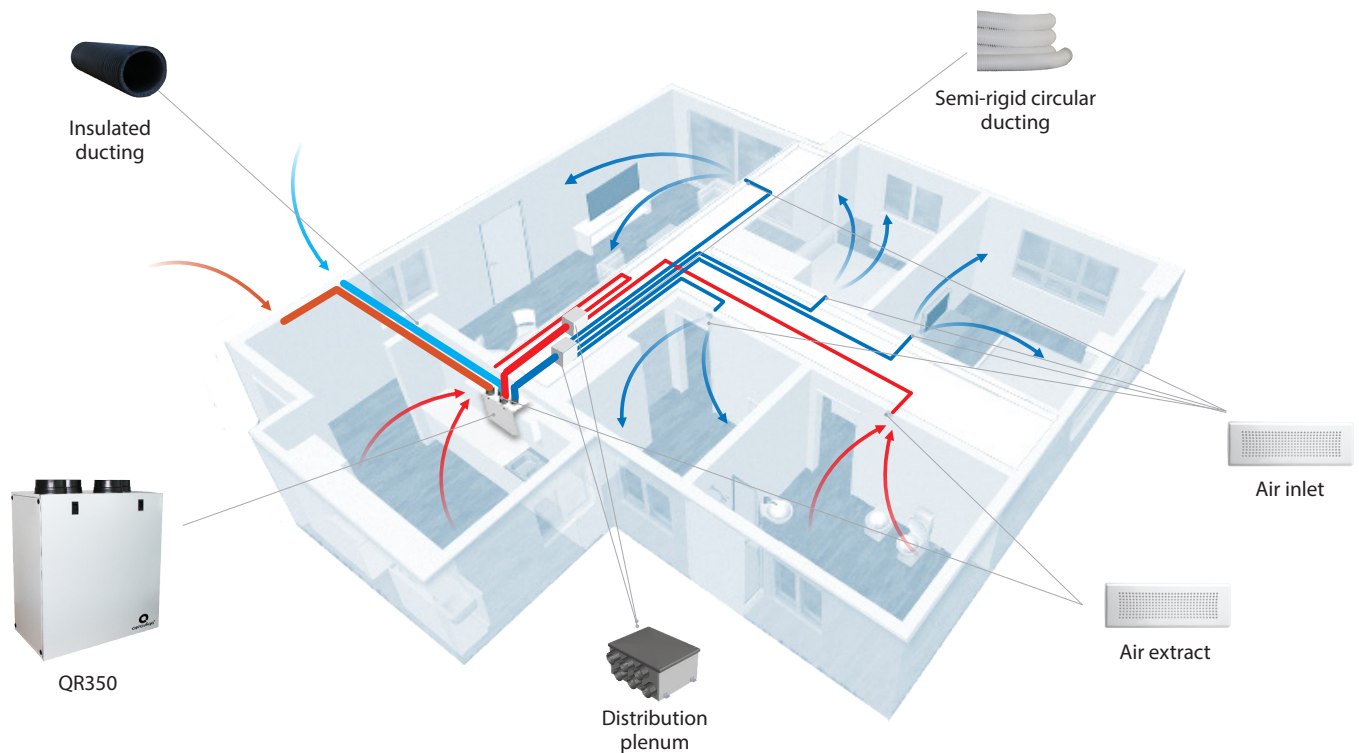

Application: new build

How it works: a continuous running heat recovery unit (QR350) transfers heat from humid air extracted from wet rooms to warm incoming fresh air which is ducted to habitable rooms. Thanks to the easy-to-fit air distribution system each single ambient can be properly ventilate: the boost function enables rapid extract of increased moisture or pollutant levels. It also provides discrete installation and very quite operation.

Energy saving: the preheated/precooled fresh air and continuous air changes reduce the demand for additional heating/air-conditioning. The EC brushless motors significantly reduce the electricity consumption.

Indoor Air Quality: a correctly specified mechanical ventilation system can ensure the quality of the indoor air is constantly maintained for the health and well-being of the occupants as well as of the building. Duly maintained filters ensure that incoming air is suitably filtered of dust and pollen before it enters the home.

Dimensions (mm)

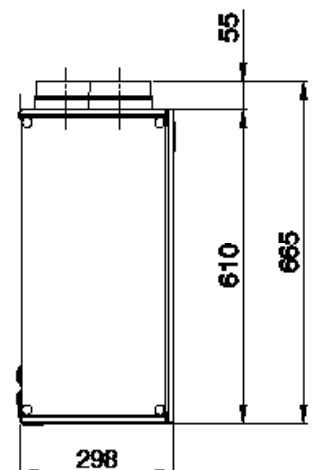
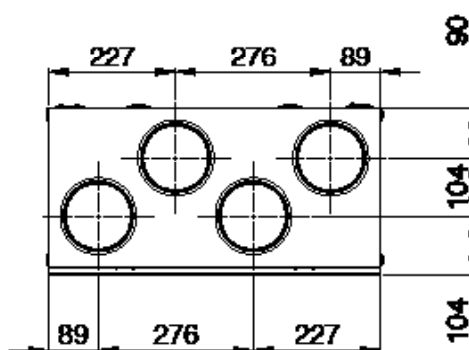
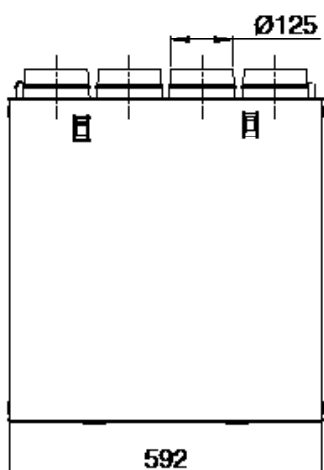

Product fiche - ErP Directive, Regulations 1253/2014 - 1254/2014

a)	Mark	-	AERAULIQA
b)	Model	-	QR350MBP - QR350ABP
c)	SEC class	-	B
c1)	SEC warm climates	kWh/m2.a	-7,3
c2)	SEC average climates	kWh/m2.a	-30,5
c3)	SEC cold climates	kWh/m2.a	-66,3
	Energy label	-	Ja
d)	Unit typology	-	Residential - bidirectional
e)	Type of drive	-	Variable speed drive
f)	Type of Heat Recovery System	-	Heat recovery
g)	Thermal efficiency of heat recovery	%	78%
h)	Maximum flow rate @ 100 Pa	m3/h	327
i)	Electric power input (alla Maximum flow rate)	W	325
j)	Sound power level (L_{WA})	dB(A)	58
k)	Reference flow rate	m3/s	229
l)	Reference pressure difference	Pa	50
m)	SEC warm climates	W/m3/h	0,541
n1)	Control factor	-	0,85
n2)	Control typology	-	Central demand control
o1)	Maximum internal leakage rate	%	1,5%
o2)	Maximum external leakage rate	%	1,5%
p1)	Internal mixing rate	%	N/A
p2)	External mixing rate	%	N/A
q)	Visual filter warning	-	Visual filter warning on display
r)	Instructions to install regulated grilles	-	N/A
s)	Internet address for preassembly/disassembly instructions	-	www.aerauliqa.com
t)	Airflow sensitivity to pressure variations	EN 13141 - 8	N/A
u)	Indoor/outdoor air tightness	EN 13141 - 8	N/A
v1)	AEC - Annual electricity consumption - warm climates	kWh	4,9
v2)	AEC - Annual electricity consumption - average climates	kWh	5,4
v3)	AEC - Annual electricity consumption - cold climates	kWh	10,7
w1)	AHS - Annual heating saved - warm climates	kWh	19,5
w2)	AHS - Annual heating saved - average climates	kWh	43,2
w3)	AHS - Annual heating saved - cold climates	kWh	84,4
	Sound pressure @ 3m*	dB(A)	34
	Ambient temperature max	°C	40
	Marking	-	C

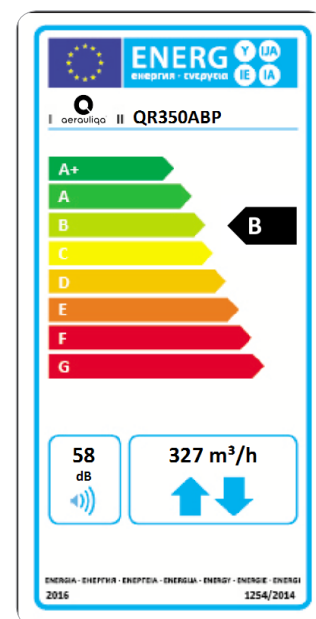

- 220-240 V ~ 50-60Hz

- Air performance measured according to ISO 5801 a 230V 50Hz, air density 1,2 Kg/m³

- data measured in the TÜV Rheinland recognised laboratory in Aerauliqa

* sound pressure level @ 3m in free field, breakout, speed 40%

QR350

Performance curve

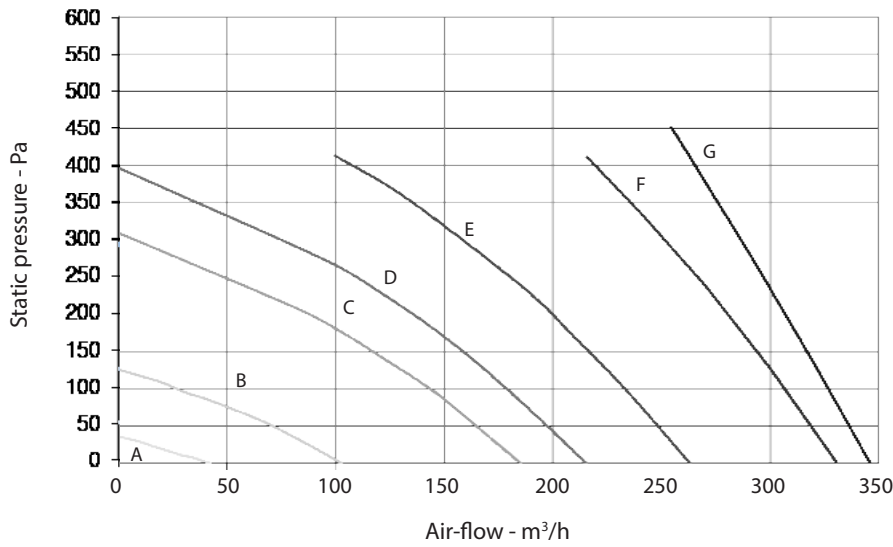

Curve	Speed %	W max	m³/h max
A (min)	20	8	43
B	35	24	103
C	50	70	185
D	60	98	215
E	67	155	263
F	85	275	330
G (max)	100	325	346

Sound level

		Lw dB - SOUND POWER OCTAVE BAND									Lp dB(A)
		63	125	250	500	1 K	2 K	4 K	8K	Tot	@3m
100%											
Intake		83	65	70	73	62	58	53	47	84	51
Supply		81	65	65	66	57	51	42	33	81	45
Extract		80	63	66	68	60	54	45	34	78	47
Exhaust		78	65	70	71	62	59	53	45	80	50
Breakout		81	69	67	69	62	56	48	36	82	48
80%											
Intake		73	61	67	69	59	56	50	43	75	47
Supply		72	61	63	65	56	50	41	31	74	43
Extract		73	60	63	65	57	51	42	31	74	44
Exhaust		73	61	66	67	58	55	49	41	75	46
Breakout		71	64	62	67	59	53	45	33	74	45
60%											
Intake		65	61	68	67	58	56	49	41	72	46
Supply		63	59	63	64	55	49	40	29	69	42
Extract		64	59	63	63	56	51	41	30	69	42
Exhaust		64	60	66	67	57	54	48	41	71	45
Breakout		59	64	63	65	57	51	43	31	70	44
40%											
Intake		55	55	67	55	49	47	40	31	68	39
Supply		53	53	62	52	47	41	32	22	63	35
Extract		58	52	60	51	47	42	32	22	63	34
Exhaust		55	54	66	55	49	47	40	31	67	39
Breakout		54	53	59	52	48	43	33	23	62	34